



Type 710BP

Precision Back Pressure Regulator

The Type 710BP Back Pressure Regulator is a high flow, highly accurate pneumatic relief valve with an adjustable set point. Its primary function is to provide protection against over pressurization in the downstream portion of a pneumatic system. This precision unit is capable of handling flows up to 50 SCFM. A rolling diaphragm provides the sensitivity that causes the Type 710BP to vent to atmosphere in response to the slightest upstream changes.

Features

- **Sensitivity**
Provides quick response to controlled system pressure variation
- **High Flow Capacity**
Flows up to 50 SCFM (depending on set point pressure and port size).
- **Compensating Flow Control**
Venturi type velocitypressure tube adjusts main control valve opening in accordance with velocity pressure variations of flow from controlled system.
- **On-Line Maintenance**
Unit can be disassembled and serviced without removing from the air line.

Applications

The Type 710BP is used in place of a standard relief valve to provide protection against excessive build-up in supply pressure lines to instruments and other sensitive control devices. The most common application is to control the air pressure in a system supplied by a compressor. Used in conjunction with a diaphragm operated inlet restricting valve and a bleed orifice, the Back Pressure regulator relieves excess compressor pressure while activating the intake restricting valve. When the regulator shuts off, the down-stream air vents through the bleed orifice allowing the restricting valve to open.

Specifications

Flow Capacity	Up to 50 SCFM (1,415 NI/min) depending on set point pressure and port size
Maximum System Pressure	250 psig (17.25 BAR)
Mounting	Pipe or Panel
Ambient Temperature	0°F to 150°F (-18°C to 66°C)
Weight	1.5 lb (.68 Kg)
Materials of Construction	Body; diecast aluminum alloy, baked enamel finish. Trim; acetal, brass, and plated steel. Knob; phenolic plastic.



Type 710BP Precision Back Pressure Regulator

Flow Characteristics

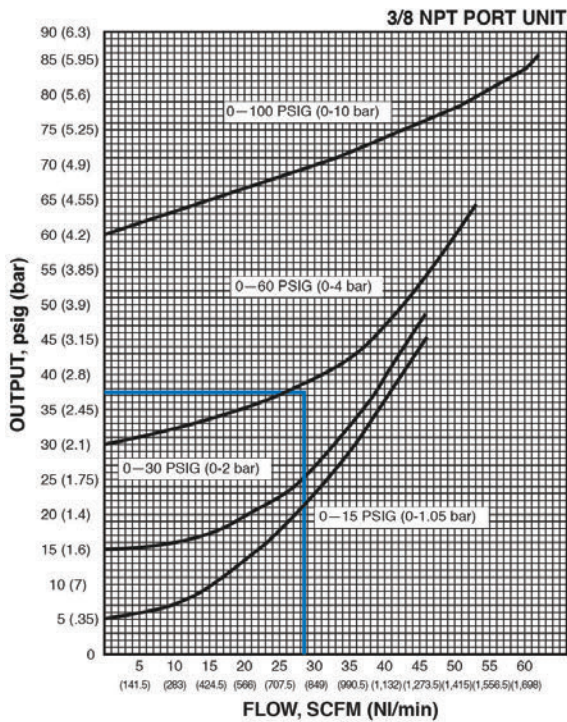

Example: The 0-60 psig range unit set at 30 psig will flow 28 SCFM with an 8 psig rise in pressure above the set point. All values assume relief flow is to atmosphere.

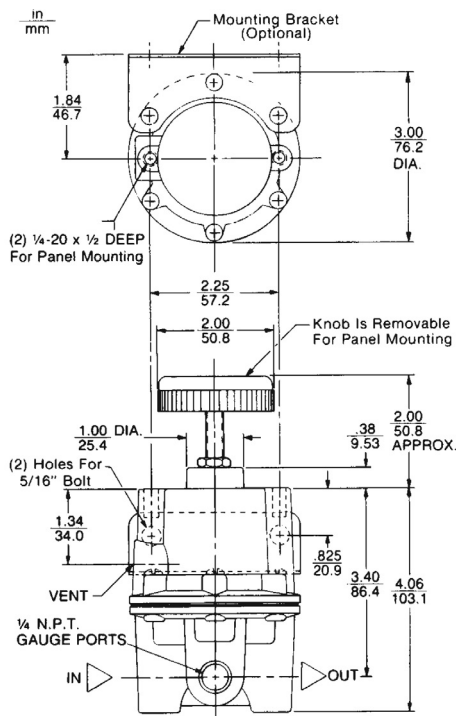

Application Example

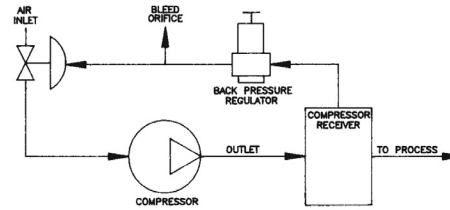

The Type 710BP is used to control the air pressure in a system supplied by a compressor. When system pressure reaches the Type 710BP set point, the unit starts relieving air pressure. This pressure is routed to an inlet valve causing it to close. Excess pressure vents through the bleed orifice and the valve opens to increase the compressor outlet pressure.

Ordering Use this coding system to order

Model

710

Port Size (NPT/BSP)

- B 1/4"
- C 3/8"
- D 1/2"

Range

- A 0-2 psi (0-0.14 BAR)
- B 0-10 psi (0-0.7 BAR)
- C 0-15 psi (0-1 BAR)
- D 0-30 psi (0-2 BAR)
- E 0-60 psi (0-4 BAR)
- G 0-100 psi (0-7 BAR)
- F 0-150 psi (0-10 BAR)

Options

- E Tapped Exhaust: allows captured exhaust. 1/4" NPT Porting
- K Knob with Stainless Steel Stem
- R EAC TR CU Certification
- S Stainless Steel Adjust Screw
- T Tamper-proof Cover
- U 1/4" BSP Porting
- X ATEX 2014/34/EU

Accessories

Mounting Bracket (zinc plated steel): P/N 446-707-025

Gauges (1/4" NPT back mount, 2" face, dual scale)

- Range: 0-15 psi (0-1 BAR) P/N 446-725-003
- Range: 0-30 psi (0-2.1 BAR) P/N 446-725-004
- Range: 0-60 psi (0-4.1 BAR) P/N 446-725-001
- Range: 0-160 psi (0-11 BAR) P/N 446-725-002

Warranty ControlAir LLC products are warranted to be free from defects in materials and workmanship for a period of eighteen months from the date of sale, provided said products are used according to ControlAir LLC recommended usages. ControlAir LLC's liability is limited to the repair, purchase price refund, or replacement in kind, at ControlAir LLC's sole option, of any products proved defective. ControlAir LLC reserves the right to discontinue manufacture of any products or change products materials, designs or specifications without notice. Note: ControlAir does not assume responsibility for the selection, use, or maintenance of any product. Responsibility for the proper selection, use, and maintenance of any ControlAir product remains solely with the purchaser and end user. Drawing downloads available at www.controlair.com



8 Columbia Drive / Amherst, NH 03031 USA / www.controlair.com / sales@controlair.com / 603-886-9400 / FAX 603-889-1844

An ISO 9001:2015 Registered Company

P/N 441-625-009 3/17/25