



## Precision Pneumatic and Electropneumatic Controls

- Current-to-Pressure (I/P) Transducers
- Voltage-to-Pressure (E/P) Transducers
- Pressure-to-Current (P/I) Transducers
- Precision Air Pressure Regulators
- Valve Positioners
- Filter Regulators
- Gas Pressure Regulators
- Volume Boosters
- Snap Acting Relays & Bias Relays
- Motorized Regulators
- Friction-free Diaphragm Air Cylinders
- Custom Engineered Devices



# ControlAir

PRECISION PNEUMATIC & ELECTROPNEUMATIC CONTROLS

## Table of Contents

Air Pressure Regulators .....	4
Air Filters .....	10
Valve Positioner .....	11
Intrinsically Safe, I/P, E/P Transducers ..	13
Explosion-Proof I/P Transducers .....	14
P/I Transducers .....	15
Integrated Process Control .....	15
Manifold .....	15
Electronic Regulators .....	17
Volume Boosters .....	19
Air Relays .....	20
Logic Relays .....	21
Diaphragm Air Cylinders .....	22

## About Us

ControlAir is a worldwide leading manufacturer of precision pneumatic and electro pneumatic control products essential to automated industrial equipment, process control systems and instrumentation, laboratory research and analysis, energy management, fluid power, robotics, and valve automation applications. An ISO-9001:2015 registered quality system assures tightly controlled specifications and processes, resulting in dependable pneumatic controls.

The company has an excellent reputation for high performance, quality products. These products include current-to-pressure (I/P) transducers, voltage-to-pressure (E/P) transducers, pneumatic-to-current (P/I) transducers, electronic regulators, precision air pressure regulators, valve positioners, filter regulators, volume boosters, motorized regulators, rolling diaphragm air cylinders and custom engineered devices. ControlAir distinguishes itself from competitors in the unique ability to adapt its products to customer-specific applications through joint development projects and strategic design partnerships.

Founded in 1987, ControlAir's dedicated effort, in combination with vast knowledge of pneumatic controls technology and its markets, has provided the company with consistent sales growth over the history of the company. Continual investment in research and development has been made in order to produce a steady stream of new products that will fuel future growth. Development of a worldwide distribution network has led to an active, international presence on every continent from North and South America to Europe, the Middle East and the Far East.

ControlAir is headquartered in a custom built engineering and production facility in Amherst, New Hampshire, USA. A technology/application center provides design capabilities for quick response to demands for product customization to fit specific application needs.

The company's capability to manufacture products to tightly controlled specifications and processes allows ControlAir to offer solutions with higher performance standards, increased dependability and tighter quality standards than might be found elsewhere in the market.

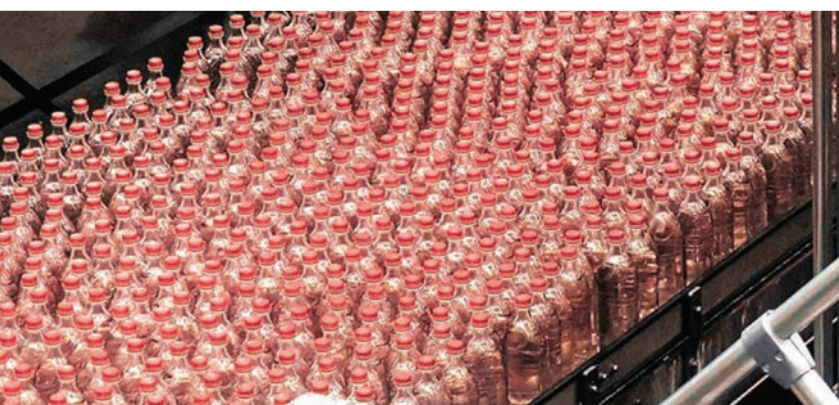



## Air Pressure Regulators

Regulator Groups	Model Series	Type	Sensitivity	Port Size								Porting		Max. Supply Pressure	Max. Output Range	Max. Flow Capacity	Body Material	
				10-32	M5	1/16"	1/8"	3/8"	1/4"	1/2"	3/4"	1"	2"					NPT
Precision	90	Sensitive	1/4" in. (6.4 mm)				X						X	X	150 psig (10 bar)	1.4-120 psig (0.1-8 bar)	14 SCFM (396 NL/min)	Aluminum Alloy
Precision	100	Sensitive	1/8 in. (3.2 mm)				X	X	X				X	X	150 psig (10.5 bar)	2-120 psig (0.14-8 bar)	14 SCFM at 100 psig supply - 20 psig outlet (420 NL/min at 6.8 bar supply; 1.4 bar outlet)	Zinc Alloy
Precision	410	Sensitive	1/2" (1.3 cm)						X				X		250 psig (17 bar)	0-100 psig (0-7 bar)	20 SCFM (570 NL/min)	Aluminum Alloy
Precision	700	Sensitive	1/8" in. (3.2 mm)					X	X	X			X	X	250 psig (17 bar)	0-150 psig (0-10 bar)	80 SCFM (2,265 NL/min)	Aluminum Alloy
Precision	7000	Sensitive, High Flow	1/2" in. (12.7 mm)					X	X	X			X		250 psig (17 bar)	0-200 psig (0-14 bar)	250 SCFM (7,079 NL/min)	Aluminum Alloy
Precision	7100	Sensitive, High Flow	1/4" in. (6.35 mm)					X	X	X			X		250 psig (17 bar)	2-120 psig (0.14-8 bar)	250 SCFM (7,079 NL/min)	Aluminum Alloy
Precision	800	Sensitive	1/2" (12.7 mm) water	X	X	X									250 psig (17 bar)	0-100 psig (0-7 bar)	5 SCFM (150 NL/min)	Anodized Aluminum
Precision	100M	Sensitive, Motorized					X	X	X				X		150 psig (10 bar)	2-120 psig (0.14-8 bar)	14 SCFM at 100 psig; 20 psig outlet (396 NL/min at 7 bar supply; 1.4 bar outlet)	
Filter	300	General Service							X				X		250 psig (17 bar)	0-120 psig (0-8 bar)	22 SCFM at 100 psig; 20 psig outlet (623 NL/min at 7 bar supply; 1.4 bar outlet)	Aluminum Alloy
Filter	310	NACE							X				X		250 psig (17 bar)	0-100 psig (0-7 bar)	20 SCFM at 100 psig; 20 psig outlet (566 NL/min at 7 bar supply; 1.4 bar outlet)	Aluminum Alloy
Filter	330	General Purpose						X	X				X		150 psig (10 bar), 250 psig (17 bar)	0-120 psig (0-8 bar)	33 SCFM (934 NL/min), 150 SCFM (4,247 NL/min)	Aluminum Alloy
Filter	335	NACE						X					X		250 psig (17 bar)	0-100 psig (0-7 bar)	33 SCFM (934 NL/min)	Aluminum Alloy
Filter	FA12	Coalescing Filter Regulator				X	X						X		0-150 psig (0-10 bar)	7-140 psig (0.5-10 bar)	Reg. 46 SCFM (1,300 nl/m)	Aluminum
Stainless Steel Filter	350	NACE					X	X					X		150 psig (10 bar), 290 psig (20 bar)	0-150 psig (0-10 bar)	160 SCFM (4530 NL/min)	316 Stainless Steel
Stainless Steel Filter	380	High Flow								X	X		X		150 psig (10 bar), 290 psig (20 bar)	0-200 psig (0-14 bar)	425 SCFM (12,034 NL/min)	316 Stainless Steel
Stainless Steel	360	NACE					X	X					X		290 psig (20 bar)	0-150 psig (0-10 bar)	160 SCFM (4530 NL/min)	316 Stainless Steel
Stainless Steel	390	High Flow							X	X			X		150 psig (10 bar), 290 psig (20 bar)	0-200 psig (0-14 bar)	425 SCFM (12,034 NL/min)	316 Stainless Steel
Stainless Steel	3600	High Pressure, NACE					X						X		6000 psig (413 bar)	0-225 psig (0-15.5 bar)	4500 SCFH	316 Stainless Steel
Pressure	340	General Service					X	X					X		250 psig (17 bar)	0-120 psig (0-8 bar)	33 SCFM (934 NL/min), 150 SCFM (4,247 NL/min)	Aluminum Alloy
Pressure	400	General Service					X						X		250 psig (17 bar)	0-120 psig (0-8 bar)	20 SCFM (570 NL/min)	Aluminum Alloy
Pressure	850	Miniature, Air	1/4" in. (6.4 mm)			X	X						X	X	150 psig (10 bar)	1.4-120 psig (0.1-8 bar)	14 SCFM (396 NL/min)	Epoxy Coated Zinc
Pressure	860	Miniature, Water	1/4" in. (6.4 mm)			X	X						X	X	150 psig (10 bar)	1.4-120 psig (0.1-8 bar)	14 SCFM (396 NL/min)	Electroless Nickel Plated Zinc
Pressure	870	Miniature, Potable	1/4" in. (6.4 mm)			X	X						X	X	150 psig (10 bar)	1.4-120 psig (0.1-8 bar)	14 SCFM (396 NL/min)	NSF Electrodeposited Chromium Plated Zinc
Pressure	3500	High Pressure					X						X		6000 psig (413 bar)	0-225 psig (0-15.5 bar)	4500 SCFH	Brass
Pressure	1227	Gas, High Flow, NACE										X	X	X	Sales Sheet Table 1	5-150 psig (0.4-10.3 bar)	Sales Sheet Table 2	LCC Steel
Pressure	1230	Gas, Pressure Reducing, NACE										X	X	X	Sales Sheet Table 1	27-500 psig (1.9-34.5 bar)	Sales Sheet Table 4	LCC Steel
Back Pressure	710	Sensitive, High Flow					X	X	X				X	X	250 psig (17 bar)	0-150 psig (0-10 bar)	50 SCFM (1,415 NL/min)	Aluminum Alloy / Aluminum
Back Pressure	7200	Sensitive, High Flow					X	X	X				X				350 SCFM (9,905 NL/min)	Aluminum Alloy
Back Pressure	855	Miniature, Air					X						X		250 psig (17 bar)	0-100 psig (0-7 bar)	35 SCFM (990 NL/min)	Epoxy Coated Zinc
Vacuum	480	Compact, Full Vacuum				X							X	N/A	0 to 30 inHg (-100 to -1.3 kPa)	1.67 SCFM (47 NL/min)		

# Air Pressure Regulators

## Type 90 Miniature Precision Air Pressure Regulator

Compact, lightweight, precise regulation



Ex ERI RoHS

- High resolution set pressure adjustment
- Highly accurate air pressure regulation in a small package
- Pressure ranges up to 120 psig (8 bar)
- Compact and lightweight
- Available in NPT and BSP porting
- Two gauge ports and reversible bracket allow front or back mounting

Flow capacity SCFM (NL/min)	14 (420)
Exhaust Capacity SCFM (NL/min)	7 (210)
Sensitivity Inch wc (mm)	.25 (6.4)
Supply Pressure max. psig (bar)	150 (10)
Approximate Size (inches)	1.38x1.38x3.88
Approximate Size (mm)	35.1x35.1x98.5

Range psig (bar)	Port Size NPT/BSP	Model# NPT/BSP*
0.70-30 (0.05-2)	1/8"	90-AA
1.4-60 (0.1-4)	1/8"	90-AB
1.4-120 (0.1-8)	1/8"	90-AC
0.70-30 (0.05-2)	Manifold	90-XA
1.4-60 (0.1-4.0)	Manifold	90-XB
1.40-120 (0.1-8)	Manifold	90-XC

\*For BSP porting add "U" to end of Model#

## Type 100 Precision Air Pressure Regulator

Dependable, highly accurate pressure regulation to 0.1%



ERI RoHS

- Accurate pressure regulation
- Stable output
- Dependable startup
- High relief capacity
- Temperature stability
- Locking capability

Models	Standard
Type 100	High Relief
Type 100HR	Extra High Relief
Type 100EHR	Low Range
Type 100LR	Plunger
Type 100PL	Bottom Ported
Type 100B	

Port Sizes NPT/BSP	1/8", 1/4", 3/8"
Output Ranges	0.5-25 psig (0.03-1.7 bar), 2-120 psig (0.14-8 bar), 2-40 psig (0.14-2.7 bar), 2-60 psig (0.14-4 bar)
Flow Capacity SCFM (NL/min)	14 (420)
Exhaust Capacity SCFM (NL/min)	Type 100: 3 (90) Type 100HR: 11 (330) Type 100EHR: 15 (450)
Sensitivity Inch wc (mm)	0.125 (3.2)
Supply Pressure max. psig (bar)	150 (10)

Approximate Size (inches)	2.0 x 2.06 x 4.26	
Approximate Size (mm)	52 x 52 x 108	
Range psig (bar)	Port Size NPT/BSP	Model# NPT/BSP*
2-40 (0.14-2.7)	1/8"	100-AA
0.5-25 (0.03-1.7)	1/4"	120-BA
2-40 (0.14-2.7)	1/8"	100-AA
	1/4"	100-BA
	3/8"	100-CA
2-60 (0.14-4)	1/8"	100-AB
	1/4"	100-BB
	3/8"	100-CB
2-120 (0.14-8)	1/8"	100-AC
	1/4"	100-BC
	3/8"	100-CC

\*For BSP porting add "U" to end of Model#

## Type 100M Motorized Precision Air Pressure Regulator

Precise pneumatic control by use of an electronic signal



RoHS

- Maintains settings during power failure
- Low power consumption
- No pre-regulation of supply pressure
- Mountable at any angle
- Adjustable mechanical stop limits
- Maximum output pressure
- Flexible range options
- Compact size

Models	Low Range	High Relief Capacity
100-MLR		
100-MHR		

Flow Capacity SCFM (NL/min)	14 (396)
Exhaust Capacity SCFM (NL/min)	Up to 10 (283)
Total Air Consumption SCFM (NL/min)	0.10 (2.83)
Supply Pressure max. psig (bar)	150 (10)

Motor Type: Reversible, synchronous motor with gear drive and slip clutch

Range psig (bar)	Approx. Time to Cover Full Range (seconds)	
	2RPM	6RPM
2-40 (0.14-2.8)	120	40
2-60 (0.14-4)	90	30
2-120 (0.14-8.3)	150	50
0.5-25 (0.03-1.7) L.R.		

## Type 300 Air Filter Regulator

Clean, accurate instrument air pressure



Ex ERI RoHS

- Provides clean, accurate air pressure
- Epoxy paint finish standard
- Stable output and repeatability
- High capacity, long lasting depth filter
- Low droop
- Low temperature option
- Filter only unit available

Filter	40 micron (5 micron option)
Flow Capacity SCFM (NL/min)	22 (660)
Exhaust Capacity SCFM (NL/min)	0.1 (3)
Sensitivity Inch wc (mm)	1.0 (25.0)
Supply Pressure max. psig (bar)	250 (17)

Range psig (bar)	Port Size NPT	Model#
0-10 (0-0.7)	1/4"	300-BD
0-30 (0-2)	1/4"	300-BA
0-60 (0-4)	1/4"	300-BB
0-120 (0-8)	1/4"	300-BC

# Air Pressure Regulators

## Type 310 NACE Air Pressure Filter Regulator

Instrument Air Filter Regulator



- Provides clean, accurate air pressure
- Epoxy paint finish standard
- Stable output and repeatability
- High capacity, long lasting depth filter
- Low droop
- Meets NACE MR-0175 requirements
- Low temperature option
- Filter only unit available



Flow Capacity SCFM (NL/min)	22 (660)
Exhaust Capacity SCFM (NL/min)	0.1 (3)
Sensitivity Inch wc (mm)	1.0 (25.0)
Supply Pressure max. psig (bar)	250 (17)

Range psig (bar)	Port Size NPT	Model#
0-10 (0-0.7)	1/4"	300-BD
0-30 (0-2)	1/4"	300-BA/310-BA
0-60 (0-4)	1/4"	300-BB/310-BB
0-100 (0-6.8)	1/4"	310-BC
N/A Filter only	1/4"	320-BX

## Type 330/335/340 Instrument Air Filter Regulator & Regulator

Type 330 Filter Regulator | Type 335 NACE Filter Regulator | Type 340 Regulator



- Lightweight compact housing with epoxy paint withstands harsh environments
- 1/4", 1/2" NPT porting
- High flow capacity
- Direct, pipe or bracket mounting
- Tapped exhaust and panel mount options
- Second gauge port
- Low temperature option
- Automatic drain option
- Type 335 meets NACE MR-0175 requirements (available in 1/4" only)

Exhaust Capacity SCFM (NL/min)	0.1 (3)
Sensitivity Inch wc (mm)	1.0 (25.0)
Supply Pressure max. psig (bar)	250 (17)
Auto Drain: Supply Pressure max. psig (bar)	150 psig (10)
Cv Values:	1/4"NPT 0.5 at 150 psig supply and 80 psig setpoint 1/2"NPT 2.5 at 150 psig supply and 80 psig setpoint

Range psig (bar)	Port Size NPT	Filter Regulator Model #	NACE Filter Regulator Model #	Regulator Model #
0-30 (0-2)	1/4"	330-BAB,	335-BAB	340-BA 340-DA
	1/2"	330-DAB		
0-60 (0-4)	1/4"	330-BBB,	335-BBB	340-BB 340-DB
	1/2"	330-DBB		
0-100 (0-7)	1/4"		335-BCB	
0-120 (0-8)	1/4"	330-BCB,		340-BC 340-DC
	1/2"	330-DCB		



## Type 350/360/370 Stainless Steel Regulators & Filter

350SS Stainless Steel Filter Regulator | 360SS Stainless Steel Regulator | 370SS Stainless Steel Filter



- Provides clean, accurate air pressure
- 1/4", 1/2" NPT porting
- Stable output and repeatability
- High capacity, long lasting depth filter
- Low droop
- Meets NACE MR-0175 requirements
- Low temperature option
- Filter only unit available

Maximum Flow Capacity SCFM (NL/min)	20 (600)
1/4" NPT	160 (4,800)
1/2" NPT	
Exhaust Capacity SCFM (NL/min)	1.0 (30)
Sensitivity Inch wc (mm)	1.0 (25.0)
Supply Pressure max. psig (bar)	290 (20)



### Type 350SS Stainless Steel Filter Regulator

Model	Part Number	Port Size (NPT)	Output Range	
			psi	bar
350-SS	350-BA	1/4"	0-30	0-2.1
350-SS	350-BB	1/4"	0-60	0-4.1
350-SS	350-BC	1/4"	0-100	0-6.9
350-SS	350-BD	1/4"	0-150	0-10.3
350-SS	350-DA	1/2"	0-30	0-2.1
350-SS	350-DB	1/2"	0-60	0-4.1
350-SS	350-DC	1/2"	0-100	0-6.9
350-SS	350-DD	1/2"	0-150	0-10.3

### Type 360SS Stainless Steel Regulator

Model	Part Number	Port Size (NPT)	Output Range	
			psi	bar
360-SS	360-BA	1/4"	0-30	0-2.1
360-SS	360-BB	1/4"	0-60	0-4.1
360-SS	360-BC	1/4"	0-100	0-6.9
360-SS	360-BD	1/4"	0-150	0-10.3
360-SS	360-DA	1/2"	0-30	0-2.1
360-SS	360-DB	1/2"	0-60	0-4.1
360-SS	360-DC	1/2"	0-100	0-6.9
360-SS	360-DD	1/2"	0-150	0-10.3

### Type 370SS Stainless Steel Filter

Model	Part Number	Port Size (NPT)
370-SS	370-BX	1/4"
370-SS	370-DX	1/2"

# Air Pressure Regulators

## Type 380/390

### Stainless Steel Filter Regulator & Regulator

380 Large Flow Capacity Stainless Steel Filter Regulator | 390 Large Flow Capacity Stainless Steel Regulator



ERC RoHS

- All 316 stainless steel construction
- 3/4" & 1" NPT ported version
- High flow capacity
- NACE approved
- Autodrain option
- Tapped exhaust

Maximum Flow Coefficients (Cv)	3/4" NPT 6.0 1" NPT 7.0
Maximum Flow Capacity SCFM (NL/min)	3/4" NPT 350 (9,905) 1" NPT 400 (11,320)
Supply Pressure max.	290 psig (20 bar)
Operating Temperature	-40° to 200°F (-40° to 93°C)
Filter	25 micron or 5 micron filter
Weight	Type 380 15 lbs (6.80 kg) Type 390 13 lbs (5.90 kg)

#### Type 380 Stainless Steel Filter Regulator

Range psig (bar)	Port Size NPT	Model#
0-30 (0-2)	3/4", 1"	380-EA, 380-FA
0-60 (0-4)	3/4", 1"	380-EB, 380-FB
0-100 (0-7)	3/4", 1"	380-EC, 380-FC
0-150 (0-10)	3/4", 1"	380-ED, 380-FD
0-200 (0-14)	3/4", 1"	380-EE, 380-FE

#### Type 390 Stainless Steel Regulator

Range psig (bar)	Port Size NPT	Model#
0-30 (0-2)	3/4", 1"	390-EA, 390-FA
0-60 (0-4)	3/4", 1"	390-EB, 390-FB
0-100 (0-7)	3/4", 1"	390-EC, 390-FC
0-150 (0-10)	3/4", 1"	390-ED, 390-FD
0-200 (0-14)	3/4", 1"	390-EE, 390-FE

## Type 3500/3600

### Accurate and Reliable First-Cut Pressure Regulator

3500 High Pressure Regulator in Brass | 3600 High Pressure Regulator in 316 Stainless Steel



RoHS

- 6000 psi max. supply
- Repeatable pressure output
- Corrosion-resistant construction
- Low cost makes this unit ideal for high volume OEM applications

Supply Pressure max. psig (bar)	6000 (413)
Temperature Range	-70° to 225°F

Range psig (bar)	Port Size NPT	Adjustment	Model#
0-30 (0-2)	1/4"	Socket	3500-BA, 3600-BA
0-60 (0-4)	1/4"	Socket	3500-BB, 3600-BB
0-125 (0-9)	1/4"	Socket	3500-BC, 3600-BC
0-150 (0-10)	1/4"	Socket	3500-BD, 3600-BD
0-225 (0-16)	1/4"	Socket	3500-BE, 3600-BE
0-30 (0-2)	1/4"	Tee Handle	3500-CA, 3600-CA
0-60 (0-4)	1/4"	Tee Handle	3500-CB, 3600-CB
0-125 (0-9)	1/4"	Tee Handle	3500-CC, 3600-CC
0-150 (0-10)	1/4"	Tee Handle	3500-CD, 3600-CD
0-225 (0-16)	1/4"	Tee Handle	3500-CE, 3600-CE

## Type 400

### General Service Regulator

Low cost, high quality, corrosion resistant and compact pressure regulation



ERC RoHS

- 1/4" NPT porting
- Stable output and reliability
- Corrosion resistant
- Low droop at high flow levels
- High quality level
- Low cost makes this unit ideal for high volume OEM applications

Flow Capacity SCFM (NL/min)	20 (600)
Exhaust Capacity SCFM (NL/min)	0.1 (3)
Sensitivity Inch wc (mm)	1.0 (25.0)
Supply Pressure max. psig (bar)	250 (17)

Range psig (bar)	Port Size NPT	Model#
0-10 (0-0.7)	1/4"	400-BD
0-30 (0-2)	1/4"	400-BA
0-60 (0-4)	1/4"	400-BB
0-120 (0-8)	1/4"	400-BC

## Type 410

### High Precision Pressure Regulator

Reliable, all purpose air regulation



- Stable Output and Reliability
- Corrosion Resistant Construction
- Low Droop at High Flow Levels
- High Sensitivity
- Low Cost

Flow Capacity SCFM (NL/min)	20 (600)
Exhaust Capacity SCFM (NL/min)	0.1 (3)
Sensitivity Inch wc (mm)	0.5" (1.3 cm)
Supply Pressure max. psig (bar)	250 (17)
Port Size	1/4" NPT

Range psig (bar)	Port Size NPT	Model#
0-2 (0-0.1)	1/4"	410-BA
0-10 (0-0.7)	1/4"	410-BB
0-30 (0-2)	1/4"	410-BC
0-60 (0-4)	1/4"	410-BD
0-100 (0-7)	1/4"	410-BE

# Air Pressure Regulators

## Type 480

### Precision Vacuum Regulator

High quality, corrosion resistant and compact pressure regulation



- Compact size and low weight allow for in-line pipe mounting
- Soft valve design provides tight shut off and eliminates leakage in steady state operation
- Versatile full vacuum control
- Easy installation with multiple mounting options

Regulating Range	0 to 30 in.Hg (-1 to -0.013 bar)	
Atmospheric Intake	.04 SCFM (1.1 NL/min)	
Sensitivity	.5 in w.c. (0.0013 bar)	
Ambient Temperature	32° to 140°F (0° to 60°C)	
Weight	.93 lbs (.42 kg)	
Port size (In and Out)	1/4 BSP	
Port size (Gauge)	1/8 BSPT (Rc1/8)	
Flow rate (max.)	3.5 SCFM (100 NL/min)	
<b>Range in.Hg (bar)</b>	<b>Port Size BSP</b>	<b>Model#</b>
0-30 (-1 to -0.013)	1/4"	480V-BA

## Type 700

### Precision Pressure Regulator

High flow capacity and accurate pressure control



- Accurate pressure control
- 1/4", 3/8", 1/2" NPT/BSP porting
- Allows flow capacity up to 80 SCFM
- Dampening action of aspirator tube provides stability under varying flow conditions
- Sensitive to minute changes in down stream pressure

EAC RoHS

Flow Capacity SCFM (NL/min)	80 (2,400)	
Exhaust Capacity SCFM (NL/min)	4 (120)	
Sensitivity Inch wc (mm)	.125 (3.2)	
Supply Pressure max. psig (bar)	250 (17)	
Approx. Size inches (mm)	DIA 3.0 (76) H 6.0 (152)	
<b>Range psig (bar)</b>	<b>Port Size NPT/BSP</b>	<b>Model# NPT/BSP*</b>
0-2 (0-0.14)	1/4", 3/8", 1/2"	700-BA, 700-CA, 700-DA
0-15 (0-1)	1/4", 3/8", 1/2"	700-BC, 700-CC, 700-DC
0-30 (0-2)	1/4", 3/8", 1/2"	700-BD, 700-CD, 700-DD
0-60 (0-4)	1/4", 3/8", 1/2"	700-BE, 700-CE, 700-DE
0-100 (0-7)	1/4", 3/8", 1/2"	700-BG, 700-CG, 700-DG
0-150 (0-10)	1/4", 3/8", 1/2"	700-BF, 700-CF, 700-DF

\*For BSP porting add "U" to end of Model#

## Type 710BP

### Precision Back Pressure Regulator

Reliable safety relief valve against over pressurization



- Sensitive protection against over pressurization in the downstream portion of a pneumatic system
- Operates as a high precision relief valve with an adjustable set point
- 1/4", 3/8", 1/2" NPT (1/4", 1/2" BSP) porting

EAC RoHS

Flow Capacity SCFM (NL/min)	50 (1,500)	
Exhaust Capacity SCFM (NL/min)	4 (120)	
Sensitivity Inch wc (mm)	0.25 (6.4)	
Supply Pressure max. psig (bar)	250 (17)	
<b>Range psig (bar)</b>	<b>Port Size NPT/BSP</b>	<b>Model# NPT/BSP*</b>
0-2 (0-0.14)	1/4", 3/8", 1/2"	710-BA, 710-CA, 710-DA
0-15 (0-1)	1/4", 3/8", 1/2"	710-BC, 710-CC, 710-DC
0-30 (0-2)	1/4", 3/8", 1/2"	710-BD, 710-CD, 710-DD
0-60 (0-4)	1/4", 3/8", 1/2"	710-BE, 710-CE, 710-DE
0-150 (0-10)	1/4", 3/8", 1/2"	710-BF, 710-CF, 710-DF

\*For BSP porting add "U" to end of Model#. BSP porting for 1/4" and 1/2" only.

# Air Pressure Regulators

## Type 7000 Precision Air Pressure Regulator

For applications that require high flow capacity



Ex EHL RoHS

- 1/4", 1/2", 3/4" NPT porting
- Two 1/4" NPT gauge ports
- High forward and exhaust flow
- Low droop and precise adjustment
- Multiple port options
- Balanced supply valve

Maximum Flow Coefficients (Cv)	Port NPT	Forward	Exhaust
	3/4"	5.0	3.5
	1/2"	4.5	3.5
	1/4"	2.0	2.5
Exhaust Capacity SCFM (NL/min)	3/4"	80 (2,264)	
	1/2"	75 (2,123)	
	1/4"	35 (991)	
Sensitivity Inch wc (mm)	0.25 (6.4)		
Effect of Supply Pressure Variation on Output	<0.3 psi (.007 bar) for 100 psi (6.7 bar) change		
Air Consumption	<12 SCFH at 200 psig output		
Supply Pressure max.	250 psig (17.5bar)		

Range psig (bar)	Port Size NPT	Model#
0-2 (0-0.15)	1/4", 1/2", 3/4"	7000-BA, 7000-DA, 7000-EA
0-10 (0-0.69)	1/4", 1/2", 3/4"	7000-BB, 7000-DB, 7000-EB
0-30 (0-2.0)	1/4", 1/2", 3/4"	7000-BC, 7000-DC, 7000-EC
0-60 (0-4.0)	1/4", 1/2", 3/4"	7000-BD, 7000-DD, 7000-ED
0-100 (0-7)	1/4", 1/2", 3/4"	7000-BE, 7000-DE, 7000-EE
0-100 (0-7)	1/4", 1/2", 3/4"	7000-BE, 7000-DE, 7000-EE
0-150 (0-10)	1/4", 1/2", 3/4"	7000-BF, 7000-DF, 7000-EF
0-200 (0-13.8)	1/4", 1/2", 3/4"	7000-BG, 7000-DG, 7000-EG

## Type 7100 Precision Air Pressure Regulator

Superior accuracy and stability with high forward and reverse flow capacity



- 1/4", 1/2", or 3/4" NPT porting
- High flow forward allows flows up to 250 SCFM
- High exhaust capacity allows relief flow up to 80 SCFM
- Balanced supply valve virtually eliminates changes to supply pressure variation
- Sensitivity to within 1/4" water column pressure
- Stable output - isolated control chamber prevents output variation under varying conditions of flow, supply pressure, and temperature
- Two 1/4" NPT gauge ports

Ex EHL RoHS

Supply Pressure max.	250 psi (17 bar)		
Air Consumption max.	14 SCFH (6.6 NL/min)		
Maximum Flow Coefficients (Cv)	Port	Forward	Exhaust
	3/4"	5.0	3.5
	1/2"	4.5	3.5
	1/4"	2.0	2.5
Exhaust Capacity SCFM (NL/min)	3/4"	80 (2,264)	
	1/2"	75 (2,123)	
	1/4"	35 (991)	
Range psig (bar)	Port Size NPT	Model#	
2-40 (0.14-2.7)	1/4", 1/2", 3/4"	7100-BA, 7100-DA, 7100-EA	
2-60 (0.14-4.1)	1/4", 1/2", 3/4"	7100-BB, 7100-DB, 7100-EB	
2-120 (0.14-8.2)	1/4", 1/2", 3/4"	7100-BC, 7100-DC, 7100-EC	

## Type 7200BP Precision Back Pressure Regulator

For applications that require high relief capacity



- 1/4", 1/2", or 3/4" NPT porting
- Two 1/4" NPT gauge ports
- Large relief valve allows flows up to 350 SCFM.
- Sensitive - reacts to pressure deviations to within 1/2" water column pressure.
- Stable performance - isolated control chamber prevents hunting and vibration during flow conditions

Ex EHL RoHS

System Pressure	250 psi (17 bar)		
Port Sizes	In/Out: 1/4", 1/2", or 3/4" NPT Gauge: (2) 1/4" NPT		
Maximum Flow Coefficients (Cv)	Port		
	3/4"	7.5	
	1/2"	6.2	
	1/4"	4.6	
Exhaust Capacity SCFM (NL/min)	Depends on port size. See flow curves on specification sheet.		

Range psig (bar)	Port Size NPT	Model#
0-2 (0-0.15)	1/4", 1/2", 3/4"	7200-BA, 7200-DA, 7200-EA
0-10 (0-0.69)	1/4", 1/2", 3/4"	7200-BB, 7200-DB, 7200-EB
0-30 (0-2.0)	1/4", 1/2", 3/4"	7200-BC, 7200-DC, 7200-EC
0-60 (0-4.0)	1/4", 1/2", 3/4"	7200-BD, 7200-DD, 7200-ED
0-100 (0-7)	1/4", 1/2", 3/4"	7200-BE, 7200-DE, 7200-EE
0-150 (0-10)	1/4", 1/2", 3/4"	7200-BF, 7200-DF, 7200-EF

## Type 800 Subminiature Precision Pressure Regulator

Precise air pressure regulation for application where space is limited



- Compact unit
- Flow capacity up to 5 SCFM
- Stable/repeatable
- Lightweight construction
- Available with threaded post/manifold mounting

Ex EHL RoHS

Flow Capacity SCFM (NL/min)	5 (150)
Exhaust Capacity SCFM (NL/min)	0.4 (12)
Supply Pressure max. psig (bar)	250 (17)
Approx. Size inches (mm)	DIA 1.0 (24.5) H 3.4 (86.4)

Range psig (bar)	1/16 NPT	Port Size 10-32	M5
0-5 (0-0.4)	800-AA	800-CA	800-BA
0-15 (0-1)	800-AB	800-CB	800-BB
0-30 (0-2)	800-AC	800-CC	800-BC
0-60 (0-4)	800-AD	800-CD	800-BD
0-100 (0-7)	800-AE	800-CE	800-BE



# Air Pressure Regulators

## Type 850/860/870 Miniature Air/Water/Potable Water Pressure Regulator

850 Air Pressure Regulator | 860 Water Pressure Regulator | 870 Potable Water Pressure Regulator



- Stable (air/water/potable water) pressure
- Small, economical package.
- Relieving and non-relieving models
- Non-rising adjustment knob with locking capability
- Lightweight construction
- OEM friendly cost
- 1/8" and 1/4" NPT/BSP porting
- Food grade compliant (870 only)

ERC RoHS

Flow Capacity:	850: 24 SCFM (697 NI/min) at 100 psig (6.9 BAR) supply, 60 psig (4.1 BAR) output 860 & 870: 2.2 gal/min.	
Supply Pressure Max	850: 250 psig (17.2 BAR) 860 & 870: 150 psig (10 BAR)	
Relief Capacity	850: 0.5 SCFM (14 NI/min) downstream pressure 10 psig (0.7 BAR) above setpoint 860 & 870: N/A	
<b>Port Size</b>		
<b>Range psig (bar)</b>	<b>1/8" NPT (BSP)</b>	<b>1/4" NPT (BSP)</b>
0-5 (0-0.4)	850/860/870-AE (CE)	850/860/870-BE (DE)
0-15 (0-1)	850/860/870-AA (CA)	850/860/870-BA (DA)
0-30 (0-2)	850/860/870-AB (CB)	850/860/870-BB (DB)
0-60 (0-4)	850/860/870-AC (CC)	850/860/870-BC (DC)
0-100 (0-7)	850/860/870-AD (CD)	850/860/870-BD (DD)

## Type 855BP Miniature Back Pressure Regulator

Protection against over pressurization in the downstream portion of a pneumatic system



- Easy and accurate adjustment
- Push-pull locking knob
- 5 adjustment ranges
- 1/4" NPT porting
- Compact and lightweight

RoHS

Relief Capacity	35 SCFM (990 NI/min)	Operating Temp	0° to 150°F (-18° to 60°C)
SMax. System Pressure	250 psig (17.2 bar)	Porting Inlet & Outlet	1/4" NPT, Gauge (2) - 1/8" NPT
<b>Port Size (NPT)</b>	<b>Output psig (bar)</b>	<b>Model#</b>	
1/4" NPT	0-5 (0-0.4)	855-BE	
1/4" NPT	0-15 (0-1.0)	855-BA	
1/4" NPT	0-30 (0-2.1)	855-BB	
1/4" NPT	0-60 (0-4.1)	855-BC	
1/4" NPT	0-100 (0-6.9)	855-BD	

## Type FA12 Filter Regulator/Coalescing Filter Combo

Oil-free air for critical applications



- 1/8" or 1/4" NPT porting
- Compact combo design
- Provides oil free air for critical applications
- Integral mounting bracket and set-point locking knob
- Clear bowl for at a glance monitoring
- Field replaceable filters
- Manual or automatic drain

Operating Pressure	7-140 psig (0.5-10 bar)		
Supply Pressure	150 psig (10.5 bar)		
Temperature Limits	23° to 140°F (-5° to 60°C) (non-freezing)		
Flow Capacities	1/8" Port - Reg. 35 SCFM (1,000 nl/m)	1/4" Port - Reg. 46 SCFM (1,300 nl/m)	
Drain Capacities	1/8" Port - 0.51 oz (15 cm <sup>3</sup> )	1/4" Port - 1.28 oz (38 cm <sup>3</sup> )	
Filtration (micron)	Regulator: 5 Filter: 0.3 or 0.01		
Mounting	Bracket (Integral)		
Ports	Supply/Output-1/8 or 1/4" NPT	Gauge Port-1/8" NPT	
Weight	0.80 lbs (0.36kg)		
<b>Port Size (NPT)</b>	<b>Filter</b>	<b>Model#</b>	
1/8"	5 micron/0.3 micron	FA12-AB	
1/8"	5 micron/0.01 micron	FA12-AC	
1/4"	5 micron/0.3 micron	FA12-BB	
1/4"	5 micron/0.01 micron	FA12-BC	

## Type 1227 High Flow Gas Pressure Regulator

Reliable pressure control for the oil and gas industry



- Wide range of orifice sizes
- 3/4", 1" or 2" body size
- Monitoring option (M) provides downstream feedback control line
- Tamper-proof cap
- Trim can be replaced without disconnecting regulator from the system
- Multiple orientations
- Superior sensitivity
- NACE MR0175 construction available
- Assembled and tested in the USA

Body Sizes	3/4", 1" or 2" NPT					
Output Ranges psi (bar)	5-20 (0.4-1.4), 15-40 (1.0-2.8), 10-95 (0.7-6.4), 35-80 (2.4-5.5), 70-150 (4.8-10.3)					
Body Inlet Pressure Rating	LCC Steel - 2,000 psi (138 bar)					
<b>Spring Range psig (bar)</b>	<b>3/32"</b>	<b>1/8"</b>	<b>Orifice Size</b>			<b>1/2"</b>
			<b>3/16"</b>	<b>1/4"</b>	<b>3/8"</b>	
5-20 (0.3-1.4)	1227X-X*CA	1227X-X*CB	1227X-X*CC	1227X-X*CD	1227X-X*CE	1227X-X*CF
15-40 (1-2.8)	1227X-X*DA	1227X-X*DB	1227X-X*DC	1227X-X*DD	1227X-X*DE	1227X-X*DF
35-80 (2.4)	1227X-X*EA	1227X-X*EB	1227X-X*EC	1227X-X*ED	1227X-X*EE	1227X-X*EF
10-95 (0.7-6.4)	1227X-X*FA	1227X-X*FB	1227X-X*FC	1227X-X*FD	1227X-X*FE	1227X-X*FF
70-150 (4.8-10.3)	1227X-X*GA	1227X-X*GB	1227X-X*GC	1227X-X*GD	1227X-X*GE	1227X-X*GF

X-X\* See catalog to select Versions and Port Sizes

## Type 1230 High Flow Gas Pressure Regulator

Reliable pressure control with wide pressure ranges and valve disk material



- Wide range of orifice sizes
- 1" or 2" body size
- Remote sensing
- Tamper-proof cap
- Trim can be replaced without disconnecting regulator from the system
- Multiple orientations
- Internal relief option
- NACE MR0175 construction available
- Assembled and tested in the USA

Body Sizes	1" or 2" NPT					
Vent Size	1/4" NPT					
Output Ranges psi (bar)	27-50 (1.9-3.5), 46-95 (3.2-6.6), 90-150 (6.2-10.3), 150-200 (10.3-13.8), 200-275 (13.8-19), 275-500 (19-34.5)					
Max. Outlet Pressure psi (bar)	500 (39.7)					
<b>Spring Range psig (bar)</b>		<b>1/8"</b>	<b>Orifice Size</b>			<b>1/2"</b>
			<b>3/16"</b>	<b>1/4"</b>	<b>3/8"</b>	
27-50 (1.9-3.5)		1230X-X*DB	1230X-X*DC	1230X-X*DD	1230X-X*DE	1230X-X*DF
46-95 (3.2-6.6)		1230X-X*EB	1230X-X*EC	1230X-X*ED	1230X-X*EE	1230X-X*EF
90-150 (6.2-10.3)		1230X-X*FB	1230X-X*FC	1230X-X*FD	1230X-X*FE	1230X-X*FF
150-200 (10.3-13.8)		1230X-X*GB	1230X-X*GC	1230X-X*GD	1230X-X*GE	1230X-X*GF
200-275 (13.8-19)		1230X-X*HB	1230X-X*HC	1230X-X*HD	1230X-X*HE	1230X-X*HF
275-500 (19-34.5)		1230X-X*IB	1230X-X*IC	1230X-X>ID	1230X-X*IE	1230X-X*IF

X-X\* See catalog to select Versions and Port Sizes

# Air Filters

## Type 320

### Air Filter

40-micron depth filter that removes dirt, moisture and other particles from air and gas lines



RoHS

- 1/4" ports
- 5 micron filter option
- Stainless steel trim option

Port Size NPT	Model#
1/4"	320-BX

Port Size	1/4" NPT
Flow Capacity (at 100 psig; 20 psig outlet)	20 SCFM (566 NL/min)
Max. Supply Pressure	250 psig (17 bar)
Ambient Temperature Limits	-20° to 160°F (-29° to 71°C), -62° to 194°F (-52° to 90°C)
Cv	0.4
Mounting	Pipe, Through Body, Bracker
Filter	40 micron, 5 micron
Weight	1.3 lb (0.59 kg)

## Type 345

### Air Filter

Rugged and reliable instrument air filtration



RoHS

- 1/4" and 1/2" port sizes
- 40 or 5 micron filter
- Autodrain capabilities
- Low temperature option: down to -62°F

Port Size NPT	Model#
1/4"	345-BX
1/2"	345-DX

Port Size	1/2" NPT, 1/4" NPT
Max. Supply Pressure	150 psig (10 bar), 250 psig (17 bar)
Max. Flow Capacity- 1/2" Ports	200 SCFM (5,660 NL/min)
Max. Flow Capacity- 1/4" Ports	80 SCFM (2,264 NL/min)
Ambient Temperature Limits	-62° to 194°F (-52° to 90°C), 0° to 160°F (-18° to 71°C), 32° to 160°F (0° to 71°C)
Filter	5 micron, 40 micron
Cv Value	0.5, 2.5
Mounting	Pipe, Bracket, Through Body
Operating Media	Air, Inert Gas, Sweet Natural Gas
Weight	1.0 lb (0.4 kg), 1.5 lbs (0.68 kg)

## Type 370

### Stainless Steel Filter

Provides clean and reliable air flow under severe conditions



- 1/4" and 1/2" ports
- Autodrain option
- Low temperature option: down to -61°F (-52°C)
- High flow capacity: up to 150 SCFM

Port Size NPT	Model#
1/4"	370-BX
1/2"	370-DX

ENEC RoHS

Port Size	1/2" NPT, 1/4" NPT
Max. Supply Pressure	150 psig (10 bar)
Max. Flow Capacity- 1/2" Ports	150 SCFM (4,247 NL/min)
Max. Flow Capacity- 1/4" Ports	50 SCFM (1,415 NL/min)
Filter	5 micron, 25 micron
Ambient Temperature Limits	-20° to 185°F (-29° to 85°C), 32° to 160°F (0° to 71°C), -61° to 194°F (-52° to 90°C)
Cv Value 1/4" , 1/2"	1.2, 3.3
Mounting	Pipe
Operating Media	Air, Inert Gas, Sweet Natural Gas, Sour Gases
Weight	2.1 lbs (0.95 kg), 2.5 lbs (1.14 kg)

## Type FA10

### Coalescing Filter

Superior filtration with high flow and minimal pressure drop



- 1/8", 1/4" or 1/2" NPT porting
- Removes liquid aerosols and sub-micron particles - liquids gravitate to the bottom of the element and will not re-enter the airstream
- Oil-free air for critical applications, such as air gauging and pneumatic instrumentation and controls.
- Low pressure droop
- Manual or automatic drain
- Clear or metal bowl

Port Size (NPT)	Filter	Model#
1/8"	0.3 micron	FA10-AB
1/8"	0.01 micron	FA10-AC
1/4"	0.3 micron	FA10-BB
1/4"	0.01 micron	FA10-BC
1/2"	0.3 micron	FA10-DB
1/2"	0.01 micron	FA10-DC

Operating Pressure Max.	150 psig (10 bar)
Proof Pressure	200 psig (15 bar)
Port Sizes	1/8" NPT, 1/4" NPT, 1/2" NPT
Flow Capacities	1/8" - 7 SCFM (200 l/m), 1/4" - 16 SCFM (450 l/m), 1/2" - 39 SCFM (1100 l/m)
Drain Capacities	1/8" - 0.51 oz (15 cm <sup>3</sup> ), 1/4" - 1.28 oz (39 cm <sup>3</sup> ), 1/2" - 1.89 oz (56 cm <sup>3</sup> )
Filtration	0.03 micron, 0.01 micron
Mounting	in-line, bracket
Weight	<b>Polycarbonate Bowl</b> <b>Metal Bowl</b>
1/8"	0.31 lbs (0.14 kg)    0.66 lbs (0.3 kg)
1/4"	0.53 lbs (0.24 kg)    1.36 lbs (0.62 kg)
1/2"	1.1 lbs (0.5 kg)    1.65 lbs (0.75 kg)

# Valve Positioner

## Type 2000 Pneumatic and Electro-Pneumatic Valve Positioner

Stable and accurate positioning of rotary and linear valves



	Pneumatic (CA2000)	Electro-Pneumatic (CA2005/CA2010/CA2011/CA2020/CA2021)	(CA2022/CA2023)
Input Signal	3-15 PSI (0.2-1.0 Bar)	4-20 mA (Ri<250 ohms)	4-20 mA (Ri<500 ohms)
Supply Pressure	<145 PSI (<10 Bar)	21.8-145 PSI (1.5-10 Bar)	21.8-100 PSI (1.5-7 Bar)
Linearity Error	<0.7 % f.s.	<1.0% f.s.	<0.8% f.s.
Hysteresis	<0.4% f.s.	<0.6% f.s.	<0.5% f.s.
Repeatability	<0.3% f.s.	<0.5% f.s.	<0.4% f.s.
Flow Capacity @29 PSI (2.0 Bar) @87 PSI (6.0 Bar) @145 PSI (10 Bar)	<b>SCFM NL/min</b> 9.5 268.9 28.3 800.1 47.1 1333	<b>SCFM NL/min</b> 9.5 268.9 28.3 800.1 47.1 1333	
Air Consumption @29 PSI (2.0 Bar) @87 PSI (6.0 Bar) @145 PSI (10 Bar)	<b>SCFM NL/min</b> 0.18 5.09 0.53 424.5 0.88 707.5	<b>SCFM NL/min</b> 0.2 5.7 0.6 17.0 1.0 28.3	
Impedance		260 Ohms @ 70 ° F	500 Ohms @ 70 ° F
Loop Load		5.2 Volts @ 20 mA	9.5 Vdc @ 20 mA
Temperature Range	-40° to 185° F (-40° to 85° C)		-40° to 158° F (-40° to 70° C)
Port Sizes	Pneumatic: 1/4" NPT; Gauge Ports - 1/8" NPT Electric: 1/2" NPT; M20-1.5 (ATEX)		
Media	Clean, dry, oil-free instrument air, filtered to 40 micron		Sweet natural gas or methane
Enclosure	Nema 4X / IP66 aluminum with polyester epoxy finish		
Weight	3.5 lbs (1.6 kg) 5.1 lbs (2.3 kg)	3.8 lbs (1.7 kg) 5.4 lbs (2.5 kg) 4.8 lbs (2.2 kg) 6.0 lbs (2.7 kg)	CA2005/CA2010/CA2011 CA2005 with feedback CA2020/CA2011 CA2022/CA2023

### Mechanical Switches (S & FS Option)

Input Signal	Honeywell V15S05-CZ100 A05-01
Switch Type	SPDT
Loop Load	5A 125/ 250 VAC/ 0.1A 48 Vdc
Operating Force	100gf
Position Feedback	<0.3% f.s.

### (F & FS Option)

Voltage	Supply 12-30 Vdc
Output	2 Wire; 4-20 mA DC
Loop Impedance	Max. 700Ω @ 24 Vdc
Linearity Error	<1.5% F.S.
Hysteresis Error	<0.5% F.S.

- Modular construction - base pneumatic unit can be quickly field converted to a fully optioned electro-pneumatic unit
- Rotary and linear, single and double acting
- External and zero adjustment for easy calibration
- Compact design - small size and low weight
- Vibration, position and shock insensitive
- Namur rotary mounting kits
- Linear mounting kits for most valves
- Stainless steel spool valve - long operating life
- High gain pilot valve - Provides quick and accurate valve/actuator response
- Standard pointed indicator (rotary), standard blank cover (linear) and optional raised beacon
- High maximum supply pressure - 145 psig (10 Bar)
- FM, CSA & ATEX approvals - for Intrinsically Safe (CA2010/CA2011) and Explosion-proof (CA2020/CA2021) operation
- Optional mechanical switches and 4-20mA position feedback

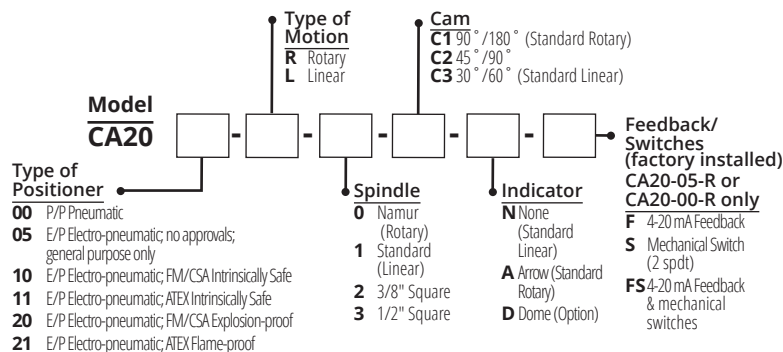



## Transducers

Transducer Groups	Model Series	Explosion-Proof	Intrinsically Safe	Input		Agency	Input Ranges	Min. Output Range	Max. Output Range	Max. Supply Pressure	Max. Flow Capacity	Port Size					
				mA	Vdc							3/16" NPT	1/8" NPT	1/4" NPT	1/2" Electric	1/16" Manifold	M20x1.5 (ATEX)
I/P, E/P	Type 500		X	X	X	FM	0-10Vdc, 0-5Vdc, 0-60mA, 1-9Vdc, 10-50mA, 4-20mA	1-17 psig (0.1-1.2 bar)	1.4-120 psig (0.1-8 bar)	150 psig (10 bar)	14 SCFM (396 NL/min)			X	X		
I/P, E/P	Type 550			X	X	FM/CSA/ATEX	0-10Vdc, 0-5Vdc, 1-5Vdc, 1-9Vdc, 4-20mA	0-30 psig (0-2 bar)	0-120 psig (0-8 bar)	150 psig (10 bar)	20 SCFM (566 NL/min)			X	X		
I/P, E/P	Type 900	X	X			FM/CSA/ATEX	0-10Vdc, 0-5Vdc, 1-5Vdc, 1-9Vdc, 4-20mA	0-15 psig (0-1 bar)	2-100 psig (0.14-6.9 bar)	105-130 psig (7.2-9 bar)	20 SCFM (566 NL/min)			X	X		
I/P	Type 590		X	X		FM/CSA/ATEX	4-20mA	3-15 psig (0.20-1.0 bar)	6-30 psig (0.40-2.0 bar)	42 psig (2.8 bar)	2.4 SCFM (67.92 NL/min)		X				
I/P	Type 590M		X	X		FM/CSA/ATEX	4-20mA	3-15 psig (0.20-1.0 bar)	6-30 psig (0.40-2.0 bar)	150 psig (10 bar)	8.36 SCFM (4.18 NL/min)					X	
I/P	Type 595	X	X	X		FM/CSA/ATEX	4-20mA	3-15 psig (0.20-1.0 bar)	6-30 psig (0.40-2.0 bar)	150 psig (10 bar)	2.4 SCFM (67.92 NL/min)			X		X	
I/P	Type 950	X	X	X		FM/CSA/ATEX	4-20mA	3-15 psig (0.20-1.0 bar)	0-33 psig (0-2.2 bar)	100 psig (7 bar)	12 SCFM (340 NL/min)			X	X		X
I/P	I/PAC	X	X	X		FM/CSA/ATEX	4-20mA	3-15 psig (0.20-1.0 bar)	0-33 psig (0-2.2 bar)	100 psig (7 bar)	12 SCFM (340 NL/min)			X			

# Intrinsically Safe I/P, E/P Transducers

## Type 500

### Electropneumatic I/P Transducer (I/P, E/P)

Economical and reliable electrical conversion to pressure



- Output pressure from 3–15 psig to 3–120 psig
- NEMA-4X (IP65) enclosure (optional)
- Integral volume booster
- Agency approvals
- Field reversible (General Purpose Unit)
- Easy span and zero adjustment
- NPT and BSP porting

	Standard Pressure	High Pressure
Flow Capacity SCFM (NL/min)	12.0 (360)	20 (600)
Terminal Based Linearity (% of span)	±0.75	±1.5
Repeatability (% of span)	<0.5	
Supply Pressure max. psig (bar)	100 (7)	150 (10)
Port Size (Pneumatic)	1/4 NPT, 1/4 BSP	
Port Size (Electric)	1/2 NPT	
Approx. Size (inches)	2.18 x 2.18 x 4.24	
Approx. Size (mm)	55.4 x 55.4 x 107.7	

Input Signal	Output Range PSI (bar)	Model# NPT/BSP*
4-20 mA	3-9 (0.20-0.6)	500-AA
4-20 mA	9-15 (0.6-1.0)	500-AB
4-20 mA	3-15 (0.2-1)	500-AC
4-20 mA	3-27 (0.2-1.8)	500-AD
4-20 mA	6-30 (0.4-2)	500-AE
4-20 mA	1-17 (0.07-1.2)	500-AF
4-20 mA	2-60 (0.14-4)	500-AG
4-20 mA	3-120 (0.2-8)	500-AH
0-5 Vdc	3-15 (0.2-1)	500-CC
0-5 Vdc	3-27 (0.2-1.8)	500-CD
0-5 Vdc	6-30 (0.4-2)	500-CE
0-5 Vdc	2-60 (0.14-4)	500-CF
0-10 Vdc	3-120 (0.2-8)	500-EH
1-9 Vdc	3-15 (0.2-1)	500-DC
1-9 Vdc	3-27 (0.2-1.8)	500-DD
1-9 Vdc	6-30 (0.4-2)	500-DE

\*For BSP porting add "U" to end of Model#

## Type 550X

### I/P, E/P Transducer

Accurate and economical miniature electronic pressure regulator



- Compact size, accessible porting and easy adjustments for limited spaces
- DIN 43650, M12, terminal block or conduit electrical connections
- DIN rail, manifold, pipe, wall or panel mounting available
- NEMA-4X(IP65) housing
- Zero based and high pressure versions
- Intrinsically safe certifications

	High Pressure	Zero Based
Inputs	4-20 mA, 0-5 Vdc, 0-10 Vdc, 1-9 Vdc	
Flow Capacity SCFM (NL/min)	12.0 (360)	20 (600)
Linearity (Independent) % of span	<±0.5	<±1.0
Repeatability % of span	<0.5	<1.0
Supply Pressure max. psig (bar)	100 (7)	150 (1050)
Port Size (Pneumatic)	1/4 NPT, 1/4 BSP	
Approx. Size (inches)	1.5 x 2.2 x 3.7	1.5 x 2.2 x 5.1
Approx. Size (mm)	38.1 x 55.4 x 93.7	1.5 x 2.2 x 5.1

Input Signal	Output Range PSI (bar)	Model# NPT/BSP*
4-20 mA	3-15 (0.2-1)	550-ACA
4-20 mA	3-27 (0.2-1.8)	550-ADA
4-20 mA	6-30 (0.4-2)	550-AEA
4-20 mA	2-60 (0)	550-AGA
4-20 mA	3-120 (0)	550-AHA
0-10 Vdc	2-60 (0)	550-EGA
0-10 Vdc	3-120 (0)	550-EHA
4-20 mA	0-30 (0)	550-AIA
4-20 mA	0-60 (0)	550-AJA
4-20 mA	0-120 (0)	550-AKA
0-10 Vdc	0-30 (0)	550-EIA
0-10 Vdc	0-60 (0)	550-EJA
0-10 Vdc	0-120 (0)	550-EKA

\*For BSP porting add "U" to end of Model#

## Type 590X

### I/P Transducer

Compact size, vibration-insensitive, electronic, pressure regulator



- Accurate pressure control at an economical cost
- Vibration and position insensitive
- Din rail and manifold mounting
- Manifold or 1/8" NPT porting available
- Wide operating temperature limits
- Worldwide safety approvals



Terminal Based Linearity (% of span)	±0.5
Supply Pressure max. psig (bar)	Manifold (M) 150 (10.0) 1/8" NPT (P) 3-15: 22 (1.5) 3-27, 6-30: 42 (2.8)
Approx. Size (inches)	3.3 x 1.4 x 2.0
Approx. Size (mm)	84.9 x 36.1 x 53.1

Input Signal	Output Range PSI (bar)	Connection	Model#
4-20 mA	3-15 (0.2-1)	Manifold	590-ACM
4-20 mA	3-27 (0.2-1.8)	Manifold	590-ADM
4-20 mA	6-30 (0.4-2)	Manifold	590-AEM
4-20 mA	3-15 (0.2-1)	1/8" NPT	590-ACP
4-20 mA	3-27 (0.2-1.8)	1/8" NPT	590-ADP
4-20 mA	6-30 (0.4-2)	1/8" NPT	590-AEP

# Intrinsically Safe I/P, E/P Transducers

## Type 900X Miniature I/P, E/P Transducer

Compact electronic pressure regulator self corrects to maintain precise control



- Shock, vibration and position insensitive
- High accuracy
- Noninteractive zero and span
- Wall, panel, pipe, DIN rail (optional) or manifold mounting
- DIN 43650, terminal block or conduit electrical connections
- NEMA-4X(IP65) Enclosure
- Supply pressures up to 130 psig
- Built-in volume booster
- Direct / reverse acting, full/split range



Inputs	4-20 mA, 0-5 Vdc, 1-9 Vdc, 0-10 Vdc, 1-5 Vdc
Flow Capacity SCFM (NL/min)	12.0 (360)
Terminal Based Linearity (% of span)	±0.10
Repeatability (% of span)	<0.10
Supply Pressure max. psig (bar)	100 (7)
Port Size (Pneumatic)	1/4 NPT, 1/4 BSP
Port Size (Electric)	1/2 NPT
Approx. Size (inches)	1.5 x 2.2 x 3.7
Approx. Size (mm)	38.1 x 55.9 x 93.7



Input Signal	Output Range PSI (bar)	Model# NPT/BSP*
4-20 mA	3-15 (0.20-1.00)	900-ACA
4-20 mA	3-27 (0.2-1.9)	900-ADA
4-20 mA	6-30 (0.4-2.1)	900-AEA
4-20 mA	1-17 (0.07-1.2)	900-AFA
0-10 Vdc	3-15 (0.20-1.00)	900-ECA
0-10 Vdc	3-27 (0.2-1.9)	900-EDA
0-10 Vdc	6-30 (0.4-2.1)	900-EEA
0-10 Vdc	1-17 (0.07-1.2)	900-EFA

Also Available	High Output	Zero Based
Inputs	4-20 mA, 0-10 Vdc, 1-9 Vdc, 0-5 Vdc, 1-5 Vdc	4-20 mA, 0-10 Vdc, 0-5 Vdc, 1-5 Vdc, 1-5 Vdc
Outputs psig (bar)	2-60 (0.14-4), 2-100 (0.14-6.9)	0-15 (0-1.0), 0-30 (0-2.1), 0-60 (0-4.1)
Supply Pressure psig (bar)	65-130 (4.5-9), 105-130 (7.2-9)	25-65 (1.7-4.5), 40-70 (2.75-4.8), 70-80 (4.8-5.5)
Air Consumption at mid range typical	4.5 SCFH (2.25 NL/min)	1.5 SCFH (0.75 NL/min)
Flow Capacity at 130 psig (9.0 bar) supply	20 SCFM (566 NL/min)	4.5 SCFM (2.25 NL/min)

Input Signal	Output Range PSI (bar)	Model# NPT/BSP*
4-20 mA	2-60 (0.14-4)	900-AGA
4-20 mA	2-100 (0.14-7)	900-AHA
0-10 Vdc	2-60 (0.14-4)	900-EGA
0-10 Vdc	2-100 (0.14-7)	900-EHA
4-20 mA	0-15 (0-1)	900-ALA
4-20 mA	0-30 (0-2.1)	900-AIA
4-20 mA	0-60 (0-4.1)	900-AJA
0-10 Vdc	0-15 (0-1)	900-ELA
0-10 Vdc	0-30 (0-2.1)	900-EIA
0-10 Vdc	0-60 (0-4.1)	900-EJA

\*For BSP porting add "U" to end of Model#

## Explosion-Proof and Vacuum Transducers

### Type 595XP Explosion-Proof I/P Transducer

High level of regulation accuracy and repeatability for the operation of actuated valves



- Compact design
- Worldwide safety approvals
- Vibration and position insensitive
- Low power consumption



Flow Capacity SCFM (NL/min)	2.4 (72)	Port Size (Pneumatic)	1/4 NPT
Terminal Based Linearity (% of span)	±0.5	Port Size (Electric)	1/2 NPT
Repeatability (% of span)	<0.3	Approximate Size (inches)	DIA 2.90 H 5.16
Supply Pressure max. psig (bar)	42 (2.8)	Approximate Size (mm)	DIA 73.7 H 131.0

Input Signal	Output Range PSI (bar)	Model# NPT/BSP
4-20 mA	3-15 (0.2-1)	595-AC
4-20 mA	3-27 (0.2-1.8)	595-AD
4-20 mA	6-30 (0.4-2)	595-AC

### Type 950XP Explosion-Proof I/P Transducer

Process reliable and field rugged electronic pressure regulator



- Compact design
- Explosion-proof NEMA-4X (IP65) enclosure
- RFI, EMI protected
- Shock, vibration and position insensitive
- Field-selectable outputs (optional)
- Highly tolerant of impure air
- Optional tapped exhaust and conduit seal required for FM/CSA approval when using natural gas (sweet) or methane



Flow Capacity SCFM (NL/min)	12.0 (360)	Port Size (Pneumatic)	1/4 NPT
Terminal Based Linearity (% of span)	±0.10	Port Size (Electric)	1/2 NPT
Repeatability (% of span)	<0.10	Approximate Size (inches)	DIA 3.50 H 4.60
Supply Pressure max. psig (bar)	100 (7)	Approximate Size (mm)	DIA 88.9 H 116.6

Input Signal	Output Range PSI (bar)	Model# NPT
4-20 mA	3-15 (0.2-1)	950-AC
4-20 mA	3-27 (0.2-1.8)	950-AD
4-20 mA	6-30 (0.4-2)	950-AE
4-20 mA	0-33 (0-2.2)	950-AF
4-20 mA	Field Selectable	950-ACA

# P/I Transducers

## P200

### Pneumatic-to-Current P/I Transducer

Explosion-proof housing allows it to stand up to the most hazardous and demanding applications



RoHS

- ±0.10% accuracy
- RFI immune

Input Signal PSI (bar)	Output Range	Model#
3-15 (0.2-1)	4-20 mA	P200 + P11
6-30 (0.4-2.0)	4-20mA	P200 + P13

Inputs	3-15 psig (0.2-1.0 bar)
Maximum Input	3 times full scale without recalibration 4 times full scale without failure
Outputs	P200: 2 wire: 4-20 mA
Allowable Loads	P200: 700 Ω
Accuracy	± 0.15% of span guaranteed; ±0.10% of span typical
Response Time	10 m Sec to 99% of step change
Temperature Stability	Span and Zero: ±0.007% of span per °F maximum deviation from 77 °F calibration
Power Supply Stability	Less than 0.005% of span change in output per volt change at the input terminals
RFI/EMI Effect	Meets or exceeds SAMA PMC 33.1, 1978, 2-abc: 0.1% of span at 10 volts/meter
Operating Temperature Range	-40 °F to 161 °F (-40 °C to 72 °C)
Storage Temperature Range	-60 °F to 161 °F (-51 °C to 72 °C)
In-process Output Monitoring	Current: For accurate reading, ammeter must have less than 20 Ω input resistance on 4-20 mA output (0.40 VDC drop)
Connections	P200: Signal Air - 1/4" NPT female Electrical Wiring - 1/2" NPT female to barrier terminal strip up to 14 AWG

## Integrated Process Control

### I/PAC

### Integrated Process Air Control

Pre-Assembled Explosion-Proof I/P Transducer with filter regulator and pressure gauge



RoHS 

- Seamless replacements for existing automated control valves in the field
- Convenient bracketing allows direct or 2" pipe mounting

- Units come preassembled with filter regulator and pressure gauge.
- Explosion-proof and intrinsically safe approvals from FM, CSA and ATEX

Input	4-20 mA
Output Range	0-33 psig (0-2.2 bar), 3-15 psig (0.2-1 bar), 3-27 psig (0.2-1.8 bar), 6-30 psig (0.4-2 bar)
Max. Supply Pressure	100 psig (7 bar)
Air Consumption	3.0 SCFH (1.5 NL/min)
Flow Capacity	12 SCFM (340 NL/min)
Housing	NEMA 4X (IP 65)
Media	Clean, dry, oil-free, instrument air, filtered to 40 micron

Input Signal	Output Range PSI (bar)	Connection	Model#
4-20 mA	3-15 (0.2-1)	Manifold	I-950-ACX-330X
4-20 mA	3-27 (0.2-1.8)	Manifold	I-950-ADX-330X
4-20 mA	6-30 (0.4-2)	Manifold	I-950-AEX-330X
4-20 mA	3-15 (0.2-1)	Manifold	595-ACX-330X
4-20 mA	3-27 (0.2-1.8)	Manifold	595-ADX-330X
4-20 mA	6-30 (0.4-2)	Manifold	595-AEX-330X

## Manifold

### Type 925

### Multi-function Supply Manifold for Type 550 or Type 900

A common supply port with individual shut-off valves



- Common supply port for the Type 550 or Type 900X I/P, E/P
- One supply line for multiple outlets
- Patented individual shut-off valve
- DIN rail mountable
- Adaptable to provide common output for solenoid valves

Connections - Supply Port	1/2 NPT
Connections - Input Stations	1/4" NPT
Number of Mountable Units	3, 5, 10, 15
Temperature Range	-4° to 190°F (-20° to 90°C)
Max. Supply Pressure	250 psig (16 bar)

Description	Model#
3 Unit Manifold Kit	438-544-005
5 Unit Manifold Kit	438-544-006
10 Unit Manifold Kit	438-544-007
15 Unit Manifold Kit	438-544-008

Kit includes manifold, mounting brackets (2), end cap, 1/2" NPT inlet fitting



## Electronic Regulators

Electronic Regulator Groups	Model Series	Feedback Monitor		Input Signal			Port Size		Min. Pressure Range	Max. Pressure Range	Monitor Output			
		Internal	External	mA	Voltage	Modbus	1/8" NPT	1/4" NPT			4-20mA	0 to 10V	1 to 5V	RS485 Modbus
Precision	1000P	X		X	X	X	X		0-30 psi (0-2 bar/4 LPM)	0-120 psi (0-8 bar/16 LPM)	X	X	X	X
Hi Flow Precision	1005P	X		X	X	X		X	0-60 psig (0-4 bar)	0-120 psi (0-8 bar/16 LPM)	X	X	X	X
Hi Flow Economic	1010P	X		X	X			X	0-120 psi (0-8 bar/16 LPM)	0-120 psi (0-8 bar/16 LPM)	X	X		
Vacuum	1005V	X		X	X			X	-14.5 to 0 psi (-1 to 0 bar/-100 to 0 kPa)	-14.5 to 0 psi (-1 to 0 bar/-100 to 0 kPa)	X	X	X	



# Electronic Regulators

## Type 1000P Electro-Pneumatic Precision Pressure Regulator

Precision control of air pressure in proportion to electrical signals



• Compact design	• High sensitivity
• High precision	• Wide pressure ranges
Input Signal	4-20mA, 0-5V, 0-10V, 1-5V, RS485
Monitor Output	4-20mA, 0-5V, 0-10V, 1-5V, RS485
Power Supply	DC24V
Response	0.8S
Operating Temp.	32° to 158° F (0° to 70° C)
Port Size	1/8" NPT
Repeatability	±0.1% full scale
Hysteresis	±0.1% full scale
Linearity	±0.1% full scale
Accuracy	±0.1% full scale
Medium	Clean compressed air or with 5 micron filter
Flow Rate scfh	8 @2 bar; 17 @4 bar; 34 @8 bar
Output Pressure Range psig (bar)	0-30 (0-2), 0-60 (0-4), 0-100 (0-7)

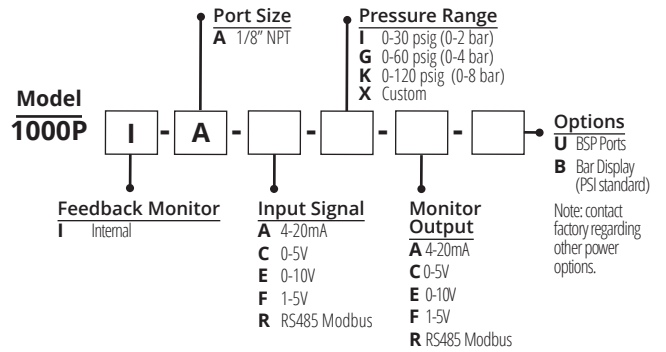

## Type 1005P Pneumatic High Flow Pressure Regulator

Handles high-volume flow rates



• Compact design	• High sensitivity
• High precision	• Wide pressure ranges
Input Signal	4-20mA, 0-5V, 0-10V, 1-5V, RS485
Monitor Output	4-20mA, 0-5V, 0-10V, 1-5V, RS485
Power Supply	DC24V
Response	0.8S
Operating Temp.	32° to 158° F (0° to 70° C)
Port Size	1/4" NPT
Repeatability	±0.1% full scale
Hysteresis	±0.25% full scale
Linearity	±0.25% full scale
Accuracy	±0.1% full scale
Medium	Clean compressed air or with 5 micron filter
Flow Rate scfh	1,271 @4 bar; 2,543 @8 bar
Output Pressure Range psig (bar)	0-60 (0-4), 0-120 (0-8)

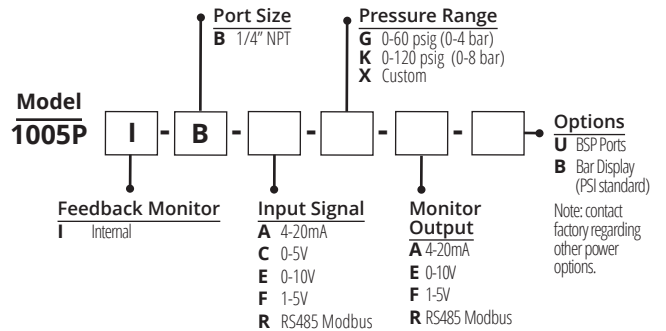

# Electronic Regulators

## Type 1010P Electro-Pneumatic Economic Pressure Regulator

Control of air pressure in proportion to electrical signals at economical cost



- Compact design
- Economical cost
- Wide pressure ranges

Input Signal	4-20mA, 0-10V
Monitor Output	4-20mA, 0-10V
Power Supply	DC24V
Response	0.8S
Operating Temp.	32° to 158° F (0° to 70° C)
Port Size	1/4" NPT
Repeatability	±0.5% full scale
Hysteresis	±0.6% full scale
Linearity	±0.5% full scale
Accuracy	±0.5% full scale
Medium	Clean compressed air or with 5 micron filter
Flow Rate scfh	2,543 @8 bar
Output Pressure Range	0-120 (0-8)

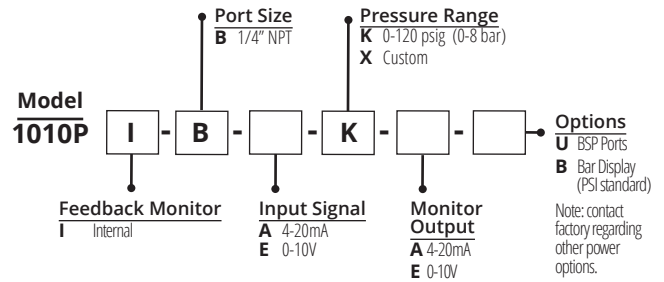

## Type 1005V Electronic Vacuum Regulator

Precise regulation and control of vacuum pressure



- Electronic closed-loop
- IP65 compliant
- Versatile control
- M12 cable

Vacuum Range	0 to -14.5 psi (0 to -1 bar / 0 to -100 kPa)
Input Signal	4-20mA, 0-10V
Monitor Output	4-20mA, 0-10V, 1-5V
Power Supply	DC24V
Electrical Connection	M12 connection
Response	0.8S
Ambient Temp.	32° to 158° F (0° to 70° C)
Port Size	1/4" NPT
Repeatability	±0.1% full scale
Hysteresis	±0.3% full scale
Linearity	±0.1% full scale
Accuracy	±0.5% full scale
Media	Clean, dry, oil-free, instrument air, filtered to 5 micron
Flow Rate	22 scfm (640L/min) @ full open

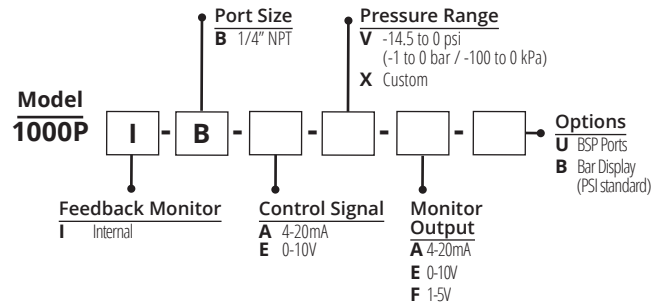

# Volume Boosters

## Type 600 Volume Booster

Ratio relay flow booster



ERC RoHS

- Signal pressure produces an output pressure with high flow capacity
- 1/4", 3/8", 1/2" NPT/BST porting
- Flow capacity to 50 SCFM
- Available with 1:1, 1:2, 1:3 or 1:6 signal to output ratio
- High relief capacity
- Negative bias option available

Flow Capacity SCFM (NL/min)	50 (1,500)	
Exhaust Capacity SCFM (NL/min)	15.0 (450)	
Sensitivity Inch wc (mm)	0.25 (6.4)	
Supply Pressure max. psig (bar)	250 (17)	
Output Pressure Range psig (bar)	0-150 (0-10)	
Approximate Size (inches)	DIA 3.0 H 3.5	
Approximate Size (mm)	DIA 76 H 85	
<b>Port Size NPT/BSP</b>	<b>Signal/Output Ratio</b>	<b>Model# NPT/BSP*</b>
1/4", 3/8", 1/2"	1:1	600-BA, 600-CA, 600-DA
1/4", 3/8", 1/2"	1:2	600-BB, 600-CB, 600-DB
1/4", 3/8", 1/2"	1:3	600-BC, 600-CC, 600-DC
1/4", 3/8", 1/2"	1:6	600-BD, 600-CD, 600-DD

\*For BSP porting add "U" to end of Model#

## Type 6000 High Flow Capacity Volume Booster

High flow capacity in a rugged casing



ERC RoHS

- 1:1 signal to output relay
- High air volume for rapid actuator stroking
- Adjustable bypass valve eliminates actuator overshoot or overdamping
- Soft seat sealing for tight shutoff
- Available in aluminum or 316 stainless steel construction
- EPDM or silicone elastomer options

Supply & Signal Pressure	150 psig (10 bar) max.	
Max Flow Coefficients (Cv)	Supply 3.0 / Exhaust 3.0	
Flow Capacity	115 SCFM (3,450 NL/min)	
Deadband	Under 0.25 psig (0.017 bar)	
Signal to Output Ratio	1:1 ± 5%	
Temperature Limits	-40° to 160°F (-40° to 71°C)	
EPDM Option "R"	-40° to 230°F (-40° to 110°C)	
Silicone Option "H"	-61° to 230°F (-52° to 110°C)	
Signal Port	1/4" NPT	
Supply/Output Port	1/2" or 3/4" NPT	
<b>In/Out Port</b>	<b>Construction</b>	<b>Model #</b>
1/2" NPT	Aluminum	6000-DA
3/4" NPT	Aluminum	6000-EA
1/2" NPT	Stainless Steel	6000-DS
3/4" NPT	Stainless Steel	6000-ES

## Type 6100/6200 High Flow Capacity Volume Booster

Rapid stroke capability in a rugged aluminum or stainless steel casing



ERC RoHS SIL3

- 1/4", 1/2", 3/4" NPT porting
- Aluminum or 316 stainless steel
- Integral adjustable bypass valve
- High flow capacity
- Soft valve seat design
- High temperature operation
- Two high output exhaust vents
- Two 1/4" NPT gauge ports
- SIL3 certifications

In/Out Port	Construction	Model #
1/4" NPT	Aluminum	6100-BA
1/2" NPT	Aluminum	6100-DA
3/4" NPT	Aluminum	6100-EA
1/4" NPT	Stainless Steel	6200-BS
1/2" NPT	Stainless Steel	6200-DS
3/4" NPT	Stainless Steel	6200-ES

Signal/Output Ratio	1:1
Supply Pressure	250 psig (17.0 bar) max.
Signal Pressure	150 psig (10.0 bar) max.
Maximum Flow Coefficients	3/4" - Forward: 5.0; 6100 Exhaust 3.5; 6200 Exhaust 4.0 1/2" - Forward: 4.5; 6100 Exhaust 3.5; 6200 Exhaust 4.0 1/4" - Forward: 2.0; 6100 Exhaust 2.5; 6200 Exhaust 3.0
Exhaust Capacity SCFM (NL/min)	3/4"-80 (2,264 NL/min), 1/2"-75 (2,123 NL/min) 1/4"-35 (991 NL/min)
Output Accuracy	1.0% of 100 psi output span
Sensitivity Inch wc (cm)	1" (2.54)
Supply Pressure Effect	0.1 psig (0.007 bar) for a 25 psig (1.7 bar) change
Signal Port	1/4" NPT
Supply/Output Port	1/4", 1/2", or 3/4" NPT
Exhaust Port	Type 6100: ø7/16" or 1/4" NPT option Type 6200: 1/2" NPT
Gauge Port (2)	1/4" NPT

## Type 6500/6600 Large Flow Capacity Volume Booster

Rapid stroke capability in a rugged aluminum or stainless steel casing



- 1:1 signal to output relays utilized in high flow applications
- Aluminum or 316 stainless steel
- 3/4" NPT or 1" NPT/BSP porting
- SIL3 certifications
- Integral adjustable bypass valve
- High temperature option
- Soft valve seat design
- Tapped high output exhaust port
- Two gauge ports - optional output feedback port
- Low temperature option

In/Out Port	Construction	Model #
3/4" NPT	Aluminum	6500-EA
1" NPT/BSP	Aluminum	6500-FA/6500-FAU
3/4" NPT	Stainless Steel	6600-ES
1" NPT/BSP	Stainless Steel	6500-FS/6500-FSU

Signal/Output Ratio	1:1
Supply Pressure	250 psig (17.0 bar) Maximum
Signal Pressure	150 psig (10.0 bar) Maximum
Maximum Flow Coefficients	3/4"-Forward: 6.0; Exhaust 5.0 1"-Forward: 7.0; Exhaust 5.0
Flow Capacity SCFM (NL/min)	3/4"-350 (9,905); 1"-400 (11,320) 100 psig (7 bar) supply, 20 psig (1.4 bar) output
Signal to Output Ratio Accuracy:	2.0% (% of 100 psi output span) 1.5% (% of 15 psi output span)
Temperature Limits	-40 to 200 ° F (-40 to 93 ° C)
Low Temperature Limits	-62 to 194 ° F (-52 to 90 ° C)
Deadband	Under 0.2 psig (.01 bar)
Supply Pressure Effect	0.3 psig (.02 bar)
Exhaust Port	ø7/16" or 1/4" NPT option
Gauge Port (2)	1/4" NPT or 1/4" BSP option

# Air Relays

## Type 200

### Precision Air Relay

Pilot operated, multi-stage 1:1 relay



- Highly Accurate
- Positive and negative bias capability
- Internal bias adjustment
- External bias adjustment
- High relief capacity
- Stable output

Flow Capacity SCFM (NL/min)	14 (420)
Exhaust Capacity SCFM (NL/min)	
Standard Relief	2.0 (60)
High Relief Capacity	10 (300)
Sensitivity Inch wc (mm)	0.125 (3.2)
Supply Pressure max. psig (bar)	150 (10)
Output Pressure Range psig (bar)	2-120 (0.14-8)
Approximate Size (inches)	2.06 x 2.06 x 2.88
Approximate Size (mm)	52 x 52 x 73

Port Size NPT/BSP psig (bar)	Max. Output Pressure	Model # NPT/BSP
<b>Standard Relief</b>		
1/4"	2-120 (0.14-8)	200-BC/200-BCU
3/8"	2-120 (0.14-8)	200-CC/200-CCU
<b>High Relief Capacity</b>		
1/4"	2-120 (0.14-8)	210-BC/210-BCU
3/8"	2-120 (0.14-8)	210-CC/210-CCU

\*For BSP porting add "U" to end of Model#

ERC RoHS

## Type 650

### Positive Bias Relay

Increases flow capacity plus adds an adjustable bias pressure



- High flow capacity - allows flows up to 50 SCFM
- Four bias ranges - from 0-15 psi to 2-150 psi
- High relief capacity - large relief valve provides 15 SCFM relief capacity
- Balanced supply valve - rolling diaphragm design makes unit insensitive to supply pressure variation
- Accurate pressure conversion - high sensitivity achieves accurate conversion of signal to output with no lag

ERC RoHS

Flow Capacity SCFM (NL/min)	50 (1,500)
Exhaust Capacity SCFM (NL/min)	15.0 (450)
Sensitivity Inch wc (mm)	0.25 (6.4)
Supply Pressure max. psig (bar)	250 (17)
Output Pressure Range psig (bar)	0-150 (0-10)
Approximate Size (inches)	DIA 3.0 H 3.5
Approximate Size (mm)	DIA 76 H 85

Port Size NPT/BSP	Bias Range PSI (bar)	Model# NPT/BSP*
1/4", 1/2"	0-2 (0-0.14)	650-BA, 650-DA
1/4", 3/8", 1/2"	0-15 (0-1)	650-BC, 650-CC, 650-DC
1/4", 3/8", 1/2"	0-30 (0-2)	650-BD, 650-CD, 650-DD
1/4", 3/8", 1/2"	0-60 (0-4)	650-BE, 650-CE, 650-DE
1/4", 3/8", 1/2"	0-150 (0-10)	650-BF, 650-CF, 650-DF

\*For BSP porting add "U" to end of Model#

## Type 7150

### Precision Air Relay

Superior accuracy and stability with high forward and reverse flow capacity



- 1/4", 1/2" or 3/4" NPT Porting
- High flow capacity
- High relief capacity allows relief flow up to 80 SCFM.
- Superior sensitivity senses output pressure deviations to within 1/4 inch water column pressure.
- Stable output - isolated control chamber prevents output variation and vibration during flow conditions.
- Balanced supply valve - virtually eliminates output pressure changes due to supply pressure variations.
- Positive and negative biasing capability
- Two 1/4" NPT gauge ports

Port Size (NPT)	Range psi (bar)	Model#
1/4"	2-120 (0.14-8.2)	7150-BC
1/2"	2-120 (0.14-8.2)	7150-DC
3/4"	2-120 (0.14-8.2)	7150-EC

Supply Pressure	250 psig (17.0 bar) maximum
Signal Pressure	120 psig (8 bar) maximum
Air Consumption	14 SCFH (6.6 NL/min)
Temperature Limits	-20 to 160 °F (-29 to 71 °C)
Maximum Flow Coefficients	3/4"-Forward: 5.0; Exhaust 3.5 1/2"-Forward: 4.5; Exhaust 3.5 1/4"-Forward: 2.0; Exhaust 2.5
Exhaust Capacity SCFM (NL/min)	3/4"-80 (2,264), 1/2"-75 (2,123) 1/4"-35 (991)
Bleed Rate	Less than 0.08 SCFM (2.3 NL/min)
Sensitivity	Less than 1/4 inch (6.3 mm) water
Bias Range	-30 psig (-2 bar) to +100 psig (6.7 bar) Max. output 120 psig (8 bar)
Effect of Supply Pressure Variation on Output	.05 psig (3.4m bar) for a 100 psig (6.9 bar) change
Mounting	Pipe, panel or bracket
Supply/Output Port	1/4", 1/2", or 3/4" NPT
Signal Port	1/4" NPT
Exhaust Port (2)	ø7/16" or 1/4" NPT option
Gauge Port (2)	1/4" NPT
Weight	2.5 lbs (1.13 kg)

## Mite

### Mite Series 70/73/74/85 Snap-acting, Pneumatic Relays

Decision making air switches



- Snap-acting design automatically trips on either an increasing or decreasing signal
- Rugged, compact units engineered for high density applications

Pressure Rating	100 psig max.
Temperature Limits	-40°F to +180°F
Port Sizes	Tapped for 1/4" NPT with 1/8" internal ports
Materials	Aluminum, plated steel, neoprene, brass and stainless steel

Description	Model#
Snap-acting control relay with manual reset. Will either lock-up or vent control pressure to a valve when tripped	Mite 70
Snap-acting air signal monitor. Accepts up to four inputs and can be reset automatically	Mite 73
Snap-acting control relay with integral 3-way or 2-way valve. Combines a Mite 70 with a precision 3-way or 2-way valve	Mite 74
Snap-acting 3-way valve with two trip points. Automatically activates back up controller if primary fails	Mite 85

## Super Mite

### 71L/71H High Pass or Low Pass Pneumatic Selecting Relay

Reliable instantaneous selection



- Automatically selects the higher or lower of two pneumatic inputs and passes it downstream while blocking the other

Pressure Rating	100 psig max.
Temperature Limits	-40°F to +180°F
Port Sizes	Tapped for 1/4" NPT with 1/8" internal ports
Materials	Aluminum, plated steel, neoprene, brass and stainless steel

Description	Model#
High pass or low pass pneumatic selecting relay. Automatically selects the higher or lower of two input signals	Mite 71L/71H

# Diaphragm Air Cylinders

## Rolling Diaphragm Cylinders

Friction-free conversion of pneumatic pressure to linear force



A rolling diaphragm provides a low-friction dynamic seal. This design provides virtually frictionless conversion of fluid pressure to linear force.

- Low hysteresis
- No blow-by leakage
- Foot & clevis mounts
- Singel acting & double acting optional
- Ultra cylinders available with linear ball bearings
- Standard units are easily modified to meet individual customer requirements

### Mounting Options

ControlAir Cylinders use 4 different main cylinder mounting styles: Universal Mount, Clevis Bracket Mount, Foot Mount and Rod Clevis Mount. Based on the intended function and system requirements, the correct mounting accessories can be selected.

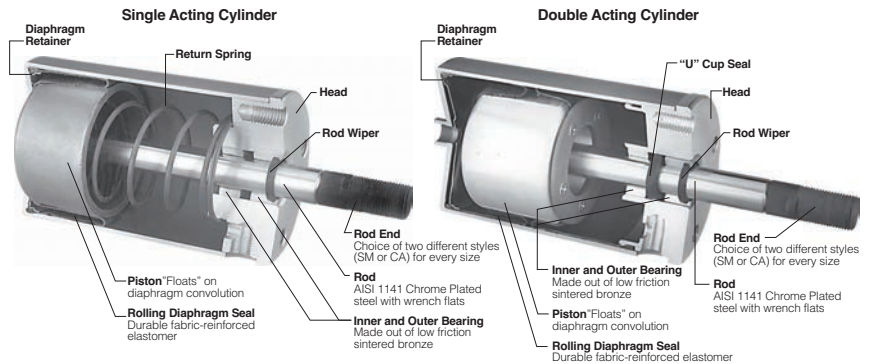

## Mini Might Cylinders

Highly sensitive, low hysteresis, friction-free performance



The Mini Mights offer the same friction free performance as ControlAir's larger sized diaphragm air cylinders. Mini Mights are based on the unique rolling diaphragm principle that virtually eliminates friction. The fact that there is no stiction or blow-by of any kind permits uncompromising accuracy and repeatability.

- Highly sensitive
- Low hysteresis
- No blow-by leakage

Pressure Rating	125 psig (8.6 bar)
Bore Sizes MM-1 and MM-2	0.7"
Stroke MM-1 or MM-2	0.7" (18mm)
Bore Sizes 1.7" diameter	1.7"
Stroke 1.7" diameter cylinder	up to 1.75"
Diaphragm Material	Reinforced Nitrile
Other Materials	Aluminium body, chrome plated steel rod, sintered bronze bearing

## Compact Cylinders



Compact cylinders are ideal for space-constrained applications or anywhere high force and shorter stroke are required.

Specifications	Part No. 139-190-002	Part No. 139-190-001
Stroke	1"	1.34"
Effective Pressure Area	1.7 in.2	1.7 in.2
Dimension A	2.2932"	3.2132"
Bore Equivalent	1.5"	1.5"
Spring Load ("0" Stroke)	4 lbs	4 lbs.
Spring Load (Max Stroke)	8 lbs.	11 lbs.
Max Operating Pressure	125 psi	125 psi
Mounting Hole Sizes	1/4"-20 UNC	1/4"-20 UNC

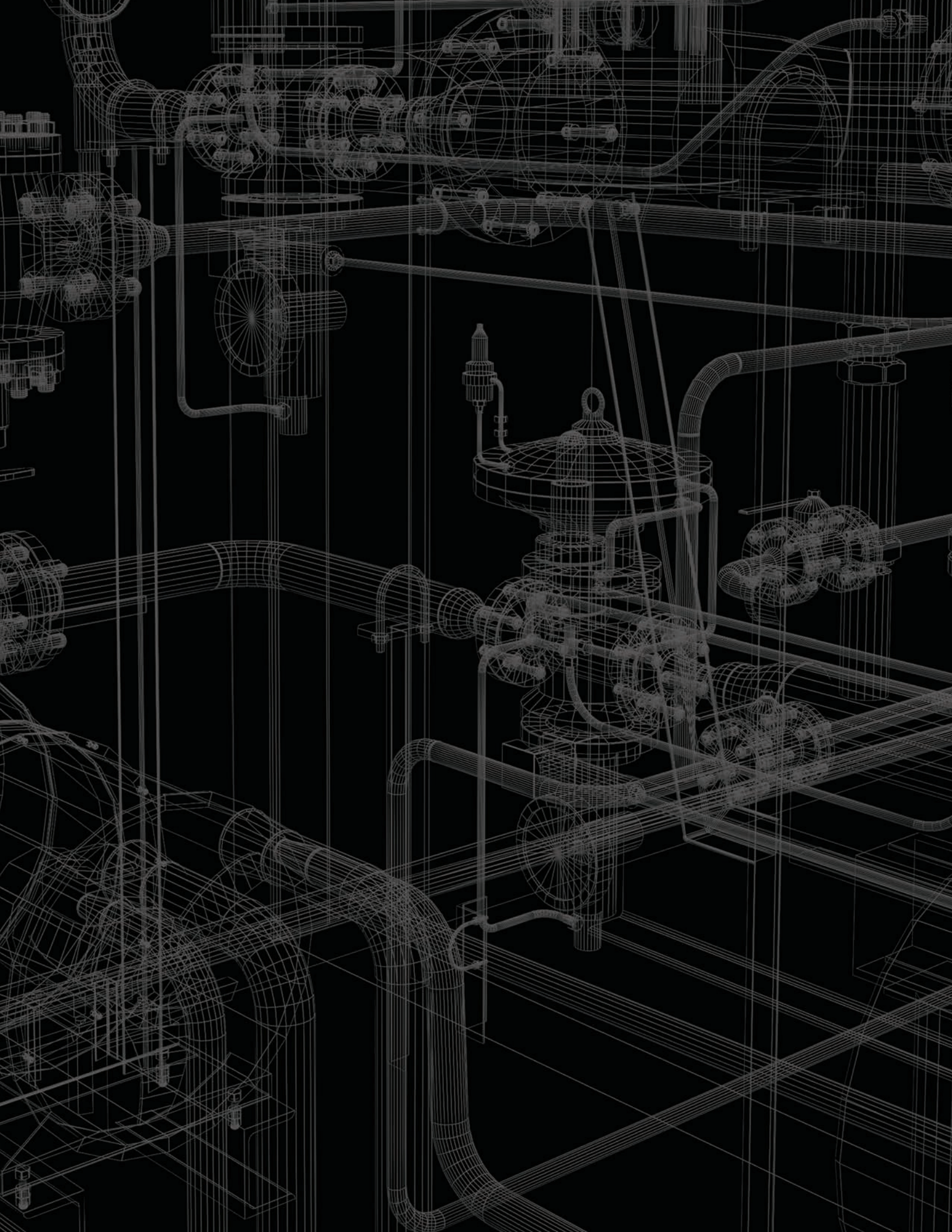

ControlAir delivers precision pneumatic and electropneumatic controls to critical industries around the world.

- MEDICAL
- VALVE ACTUATION
- PAPER & PULP
- OIL & GAS
- MARINE OFFSHORE
- FOOD PROCESSING
- Automated Industrial Equipment
- Process Control Systems
- Laboratory Research & Analysis
- Energy Management
- Fluid Power
- Robotics
- Valve Automation

Get the details on any ControlAir product and find a distributor in your area.

Log onto [www.controlair.com](http://www.controlair.com)

- Browse our entire product line
- View complete specifications and performance data
- Download product specs and 2D/3D CAD models

Or call 603-886-9400 for more information and a full product catalog



Partner with a global company that delivers top-quality products and highly-personal, friendly service.

- Over 30 years of innovation in precision pneumatic and electro-pneumatic controls
- World-wide distribution
- ISO 9001:2015 registered manufacturing
- Unparalleled expertise

**TRY US...WE'RE EASY!**



Distributed by:

 **ControlAir**

PRECISION PNEUMATIC & ELECTROPNEUMATIC CONTROLS

8 Columbia Drive / Amherst, NH 03031 USA

Website: [www.controlair.com](http://www.controlair.com)

Email: [sales@controlair.com](mailto:sales@controlair.com)

603/886-9400 Fax: 603/889-1844

An ISO 9001 Registered Company

12/18/24 P/N: 441-625-013