



Type 950XP

Explosion-Proof I/P Transducer

Process-reliable and field rugged

Approved
for
Natural
Gas

The Type-950XP Explosion-proof I/P (current to pressure) transducer produces a pneumatic output that is directly proportional to a current input signal. A closed loop pressure feedback control system provides a highly accurate, stable air pressure output for the operation of actuated valves. The unit can mount in any position and is vibration insensitive. Its compact housing and easily accessible ports and adjustments make set-up and installation of the unit simple. An integral volume booster provides high flow capacity, which increases control speed in critical applications.

Features

- **Optional Field-Selectable Outputs**
Allows you to stock only one unit for all outputs
- **Approved for Natural Gas**
When purchased with option (E)
- **RFI/EMI Protected**
Eliminates susceptibility to electromagnetic interference
- **Compact Size** Installs where others won't
- **Low Air/Gas Consumption**
3.0 scfh at mid range



Type 950XP

 Reliable performance and value in a compact, explosion-proof

Now, there is a compact I/P transducer that delivers reliable high performance for the toughest applications in the most hazardous environments: the Type 950XP from ControlAir. The 950XP converts an electrical current signal to a stable, pneumatic output to actuate valves. Its NEMA 4X (IP65) housing is designed for both Intrinsically Safe and Explosion-Proof operation. Advanced circuitry includes electronic feedback control for superior vibration protection and highly accurate output.

With flow rates up to 12 scfm (340 NL/min), the 950XP has the muscle to drive large valves and actuators. It is very economical to operate, consuming only .05 scfm (1.42 NL/min), which is especially important in natural gas applications.

Its small footprint can fit into tight spots. An optional mounting kit lets you mount it directly on a valve, wall, panel, or 2" pipe. Optional field-selectable process output ranges reduce downtime and inventory. And since the 950XP is position insensitive, it provides even more freedom in mounting and connecting to valves and instruments. As a result of this flexibility, installation goes faster. Easy access Zero and Span adjustments make bench or field calibration quick and easy.

For operating versatility, you may choose direct, reverse, and split range modes. A piezoelectric bimorph actuator and surface-mounted electronics are conveniently mounted on a removable control manifold that allows easy maintenance. The 950XP can be out-of-the-box and up-and-running quickly.

Whether designing a new control system or upgrading an old one, the Type 950XP is the best unit for the job. It is a great combination of performance and value. Get in touch with ControlAir today and one of our application specialists will be happy to discuss your needs.

Principles of Operation

The Type-950XP utilizes a nozzle to control a pilot pressure to an integral volume booster. The resultant output pressure is measured by a pressure sensor, which in turn provides a feedback signal to the control circuitry.

The feedback circuit compares this signal to the input signal and self corrects as necessary, thus minimizing the effects of vibration, position, temperature and supply pressure. The current signal flows to the piezo actuator causing it to bend toward the nozzle. This restricts the flow of air through the nozzle and creates back pressure in the pilot pressure chamber. This back pressure acts as a signal pressure which in turn controls the pressure at the output.

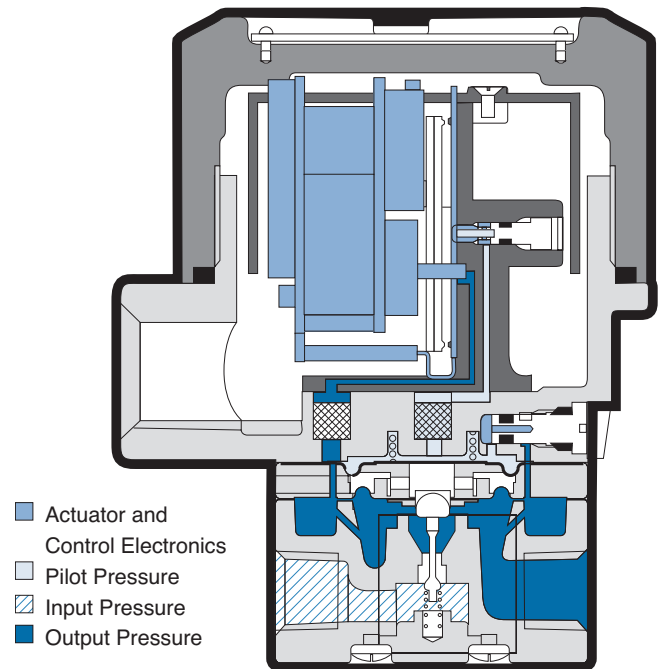

Functional Specifications

Inputs	4-20 mA	Flow Capacity	4.5 scfm (127 NL/min) at 25 psig (1.7 bar) supply 12.0 scfm 340 NL/min) at 100 psig (7.0 bar) supply
Note: Extended periods of electrical input without supply air pressure may damage unit		Note: Multiply flow value by 1.29 for Natural Gas	
Outputs	3-15 psig 0.20-1.00 bar 3-27 psig 0.20-1.80 bar 6-30 psig 0.40-2.00 bar 0-33 psig 0-2.2 bar	Temperature Limits	Operating -40° to +158° F (-40° to +70° C) Storage -40° to +200° F (-40° to +93° C)
Air Consumption	3.0 scfh (1.5 NL/min) at mid range	Loop Load, I/P Transducer	9.5 VDC @ 20 mA (500 Ohms resistance)
Note: Multiply by 1.29 for Natural Gas		Operating Modes	direct, reverse and split range (Split ranging not possible with field selectable option)
Supply Pressure psig (bar)	3-15 (0.2-1.0), 3-27 (0.2-1.8), 6-30 (0.4-2.0); 100 psig (7.0 bar) maximum 0-33 (0-2.2): 70 psig (4.7 bar) maximum		
Note: Supply pressure must be a minimum of 5 psig above maximum output			

Explosion-proof, NEMA 4X (IP65) housing

Approved for natural gas

Compact size

Easy wiring

Low air consumption

High output flow capacity

Position-insensitive—can be mounted in any orientation

RFI/EMI protected

Supply pressures up to 100psig

Electronic feedback control for superior shock and vibration resistance

Optional field-selectable output ranges

Optional tapped exhaust

High accuracy $\pm 0.10\%$ of span

Input/output ports on front and back



Performance Specifications

Accuracy, Hysteresis, and Repeatability	$\pm 0.10\%$ of span (± 0.25 with field-selectable option)
Deadband	0.02% of span
Position Effect	No measurable effect
Vibration Effect	Less than $\pm 1.0\%$ of span under the following conditions: 5-15Hz @ 0.8 inches constant displacement; 15-500Hz @ 10g's
Supply Pressure Effect	No measurable effect
Temperature Effect	$\pm 0.045\%/^{\circ}\text{F}$ ($0.07\%/^{\circ}\text{C}$) of span
Reverse Polarity Effect	No damage from reversal of normal supply current (4-20 mA) or from misapplication of up to 60 mA
RFI/EMI Effect	Less than .5% of span change in output pressure per En 61000-4-3:1998, Amendment 1, Performance Criterion A

Physical Specifications

Port Sizes	Pneumatic	1/4" NPT
	Electric	1/2" NPT M20 x 1.5 (ATEX)
Media	Clean, dry, oil-free, air-filtered to 40 micron Sweet natural gas or methane when purchased with the (E) option.	
Mounting	Direct wall, panel, or 2" pipe (optional)	
Materials	Housing	Chromate-treated aluminum with epoxy paint. NEMA 4X (IP65)
	Elastomers	Buna-N
Weight	Trim	Stainless steel; brass; zinc-plated steel
		1.8 lbs (0.82 kg) 2.3 lbs (1.1 kg) with (E) option

Type 950XP Explosion-Proof I/P Transducer

Ordering Use this coding system to order

Model

950

Input Signal

A 4-20 mA

Output psig bar

C 3-15 0.2-1.0
 D 3-27 0.2-1.8
 E 6-30 0.4-2.0
 F 0-33 0-2.2

Options

- A** Field selectable outputs* (0.25% accuracy)
- E** Approved (FM/CSA or ATEX) for Natural Gas media. (Includes tapped exhaust and factory sealed conduit assembly)
- K** ATEX Explosion-proof Intrinsically safe (Units come standard as FM/CSA Explosion-proof Intrinsically safe) (not available for output "F")
- T** Tapped Exhaust (1/8" NPT)

* Field selectable option is available only for units with the following outputs: 3-15 psig, 3-27 psig, 6-30 psig.

Accessories

Mounting kit for 1.5" or 2" pipe. Kit # 448-542-005

Hazardous Area Classification

Factory Mutual (FM) & Canadian Standards (CSA) Approvals

Zone Certification	Entity Parameters	Temperature Code	Enclosure
Explosion-Proof Class I, Division 1, Groups B, C & D Class II & III, Division 1, Groups E, F, & G Class I, Division 2, Groups A, B, C & D	---	T6 Ta=+70°C	Nema-4X
Intrinsic Safety Class I, Division 1, Groups C & D Class II, Division 1, Groups E, F, & G Class III, Division 1; Fibers	Vmax = 30 Vdc Imax = 125 mA Pi = 0.7 W Ci = 0 nF Li = 0 mH	T4 Ta=+70°C	Nema-4X

Suitable for use with methane or natural gas supply pressure media when ordered with tapped exhaust and factory sealed conduit assembly (Option E)

ATEX Approval ("K" Option)

Zone Certification	Entity Parameters	Temperature Code	Enclosure
Intrinsic Safety Ex II 1 G Ex ia IIB Ga	Vmax = 30 Vdc Imax = 125 mA Pi = 0.7 W Ci = 1 nF Li = 2.2 mH	T4 -40°C ≤ Ta ≤ +70°C	IP65
Flameproof Ex II 2 G Ex d II B + H2 Gb	---	T6 -20°C ≤ Ta ≤ +70°C	IP65
Limited Energy/Non-Sparking Ex II 3 G Ex nA nL IIC Gc	---	T6 -40°C ≤ Ta ≤ +70°C	IP65

Suitable for use with methane or natural gas supply pressure media when ordered with tapped exhaust and factory sealed conduit assembly (Option E)



Dimensions

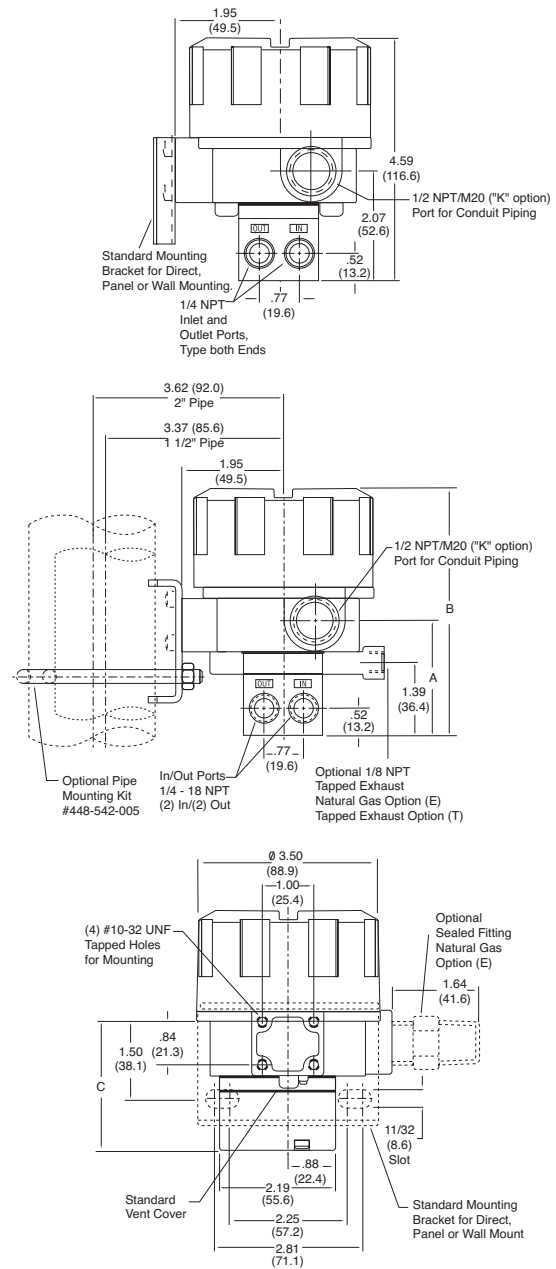

Warranty ControlAir LLC products are warranted to be free from defects in materials and workmanship for a period of eighteen months from the date of sale, provided said products are used according to ControlAir LLC recommended usages. ControlAir LLC's liability is limited to the repair, purchase price refund, or replacement in kind, at ControlAir LLC's sole option, of any products proved defective. ControlAir LLC reserves the right to discontinue manufacture of any products or change products materials, designs or specifications without notice. Note: ControlAir does not assume responsibility for the selection, use, or maintenance of any product. Responsibility for the proper selection, use, and maintenance of any ControlAir product remains solely with the purchaser and end user. Drawing downloads available at www.controlair.com



8 Columbia Drive / Amherst, NH 03031 USA / www.controlair.com / sales@controlair.com / 603-886-9400 / FAX 603-889-1844

An ISO 9001:2015 Registered Company

P/N 441-625-022 2/10/26