

# Type 950XP

# Explosion Proof I/P Transducer

## Installation, Operation and Maintenance Instructions

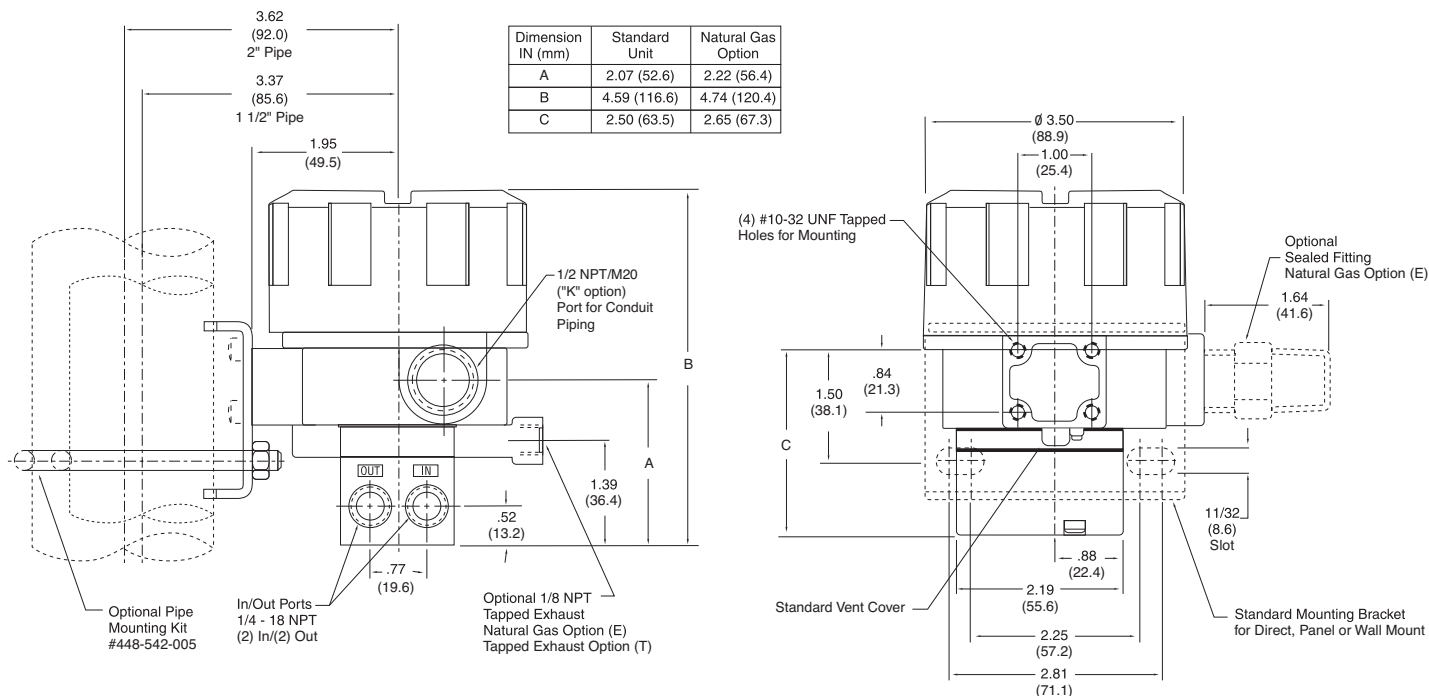

### Use this coding system to order

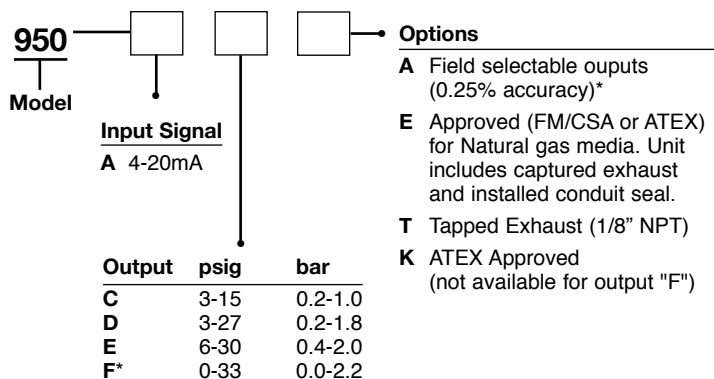

\*Field selectable option is available only for units with the following outputs: 3-15 psig, 3-27 psig, 6-30 psig

### Contents

Section	Description	Page
1.0	Installation & Approvals	3
2.0	Operation	6
3.0	Maintenance & Repairs	8
4.0	Troubleshooting	8
5.0	Warranty	8



8 Columbia Drive / Amherst, NH 03031 USA  
 Website: [www.controlair.com](http://www.controlair.com)  
 Email: [sales@controlair.com](mailto:sales@controlair.com)  
 603-886-9400 FAX 603-889-1844

An ISO-9001:2008 Certified Company





# 1. INSTALLATION AND APPROVALS

## 1.1 Pre-installation Requirements

- 1.1.1 Environment: Suitable for installation in the following locations:
- Intrinsically safe operation in hazardous locations outdoors (NEMA 4X, CSA.ENC.4 & IP65)
  - Explosion Proof Installation in hazardous locations outdoors (NEMA 4X, CSA.ENC.4 & IP65)
  - See section 1.5, 1.6 and 1.7 for Factory Mutual, Canadian Standards and ATEX approvals.

**WARNING** *The I/P transducer enclosure contains aluminum and is considered to constitute a potential risk of ignition by impact or friction. Care must be taken into account during installation to prevent impact or friction.*

**DANGER** *All wiring must be made to all local and national codes appropriate to the area of installation.*

- 1.1.2 Electrical Input: 4-20 mA dc current source. It is recommended that shielded cable be used and that the shield be grounded to unit and earth ground. See Figure 1 on page 4 for location of ground screw.
- 1.1.3 Air supply: Clean, dry, oil free instrument air filtered to 40 micron
- 1.1.4 If the Natural gas option (E) is selected, the unit is suitable for use with natural gas media as approved by Factory Mutual (FM) and Canadian Standards Association (CSA or ATEX). Natural gas option (E) includes tapped/captured exhaust and installed sealed conduit fitting. Removal of conduit fitting will void approvals (FM/CSA or ATEX) for use with natural gas media.
- 1.1.5 For ATEX approved unit, customer must mark label by adding a tick mark in the appropriate box that corresponds to the type of hazardous area installation (i.e. Ex d, Ex ia or Ex nL). See Figure 1.

**CAUTION** *Use caution not to scar threads of fitting during installation as this can void integrity of the seal.*

**CAUTION** *Exhaust gas must be vented to a safe area.*

## 1.2 Mounting

- 1.2.1 The Type 950XP has been designed to mount inline, to a standard valve yoke (bracket included with unit), or to a 1.5" (3.8 cm) or 2" (5.1 cm) pipe (optional mounting kit 448-542-005 required).

## 1.3 Pneumatic Connections

- 1.3.1 Clean all pipe lines to remove dirt and scale prior to installation.
- 1.3.2 Supply air must be filtered to 40 microns and free of moisture and lubricants.
- 1.3.3 Two (2) 1/4" NPT ports are provided for supply air connections. Either port may be used. The unused port must be plugged with the pipe plug included with the unit.
- 1.3.4 Two (2) 1/4" NPT ports are provided for pneumatic output connections. Either port may be used and one may be used for the mounting of an output gauge. If no gauge is installed, the unused port must be plugged with the pipe plug included with the unit.

## 1.4 Electrical Connections

- 1.4.1 The Type 950XP is supplied with a 1/2" NPT electrical conduit connection as standard, M20 - 1.5 for ATEX option.
- 1.4.2 A two (2) position terminal block that is wire ready is supplied for 22-12 AWG wire. Wire should be stripped approximately 1/4" before insertion. The terminals are labeled "+" and "-" on the terminal board (see figure 1).
- 1.4.3 It is recommended that shielded cable be used and that the shield be grounded at the unit (ground screw provided) and to earth ground.

**CAUTION** *Do not apply electrical input for extended periods without supply air pressure being present.*

**NOTE** *Observe polarity. Reverse polarity will not damage the unit, but unit will not operate.*

**CAUTION** *Conduit should be connected to prevent condensation from collecting in the unit.*

**Figure 1 Type 950XP**

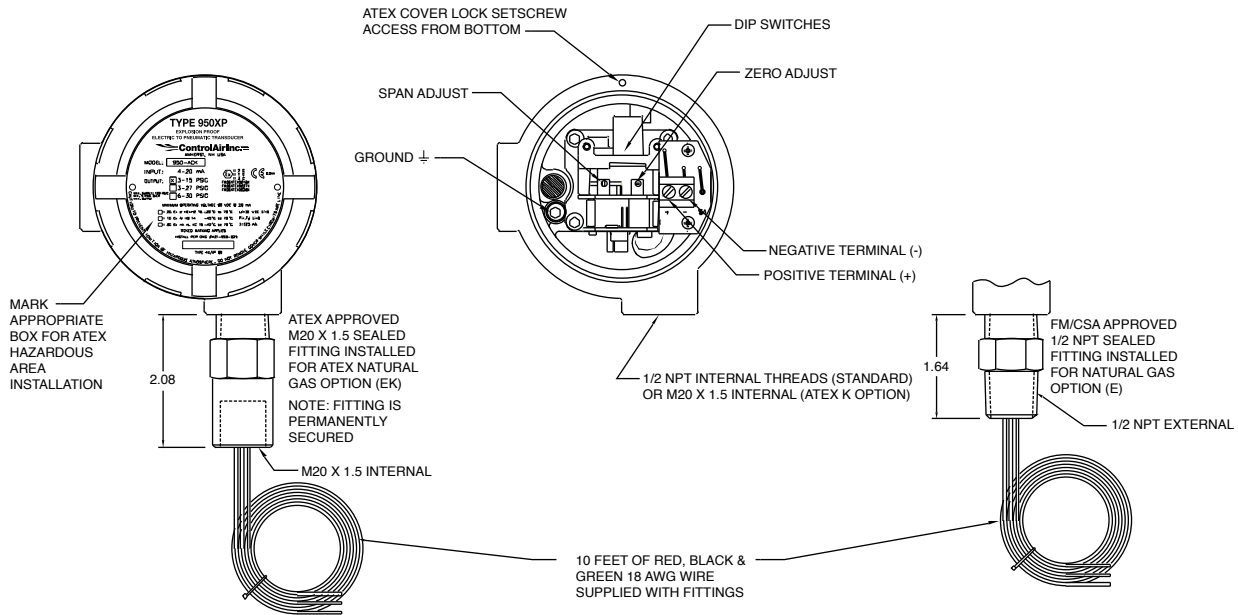

**1.5 Factory Mutual Research Corporation (FM) and Canadian Standards Association (CSA)**



**Intrinsically Safe**

Class I, Division 1, Groups C & D  
 Class II, Division 1, Groups E, F, & G  
 Class III, Division 1, Fibers  
 Enclosure Nema 4X(IP65)  
 Rated 4-20 mA, 30 VDC Max.  
 Temp. Code T4

**Explosion Proof**

Class I, Division 1 & 2, Groups B, C & D  
 Enclosure Nema 4X (IP65)  
 Temp. Code T6

**Dust Ignition Proof**

Class II & III, Division 1, Groups E, F & G  
 Enclosure Nema 4X(IP65)  
 Temp. Code T6

**Non-Incendive**

Class I, Division 2, Groups A, B, C & D Temp. Code T4  
 Class II, Division 2, Groups F & G  
 Class III, Division 2, Fibers  
 Enclosure Nema 4X(IP65)  
 Temp. Code T6

**Entity Parameters**

$V_{max} = 30 \text{ VDC}$     $C_i = 0 \text{ uF}$   
 $I_{max} = 125 \text{ mA}$     $L_i = 0 \text{ mH}$

**Entity Installation Requirements**

$V_{max} \geq V_t \text{ OR } V_{oc}$   
 $I_{max} \geq I_t \text{ OR } I_{sc}$   
 $C_a \geq C_i + C_{cable}$   
 $L_a \geq L_i + L_{cable}$

Note: Cable capacitance and inductance must be considered when connecting to pressure transducer.

# 1.6 ATEX Approvals (option K)

FM06ATEX0018X II 2 G Ex db IIB + H2 T6 Gb Ta = -20° C to +70° C  
 FM06ATEX0027X II 1 G Ex ia IIB T4 Ga Ta = -40° C to +70° C  
 FM06ATEX0028X II 3 G Ex nA nL IIC T6 Gc Ta = -40° C to +70° C

**Entity Parameters**  
 Ui (Vmax) = 30 VDC Ci = 0 uF  
 li (Imax) = 125 mA Li = 0 mH  
 Pi = .7 W Max.



## Installation Drawing No. 431-990-025

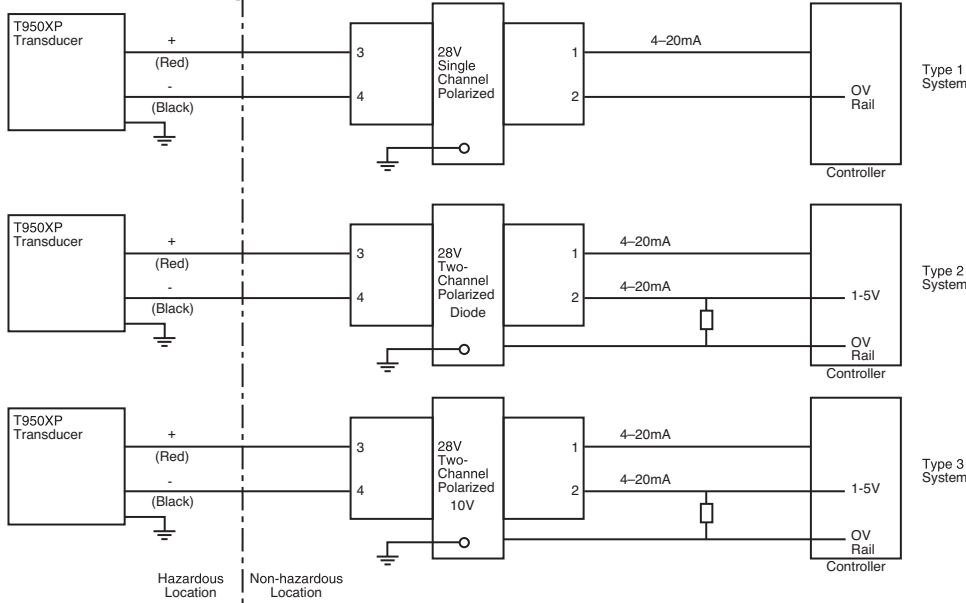

### Notes:

- Control equipment connected to the Associated Apparatus must not use or generate more than 250 Vrms or Vdc.
- The IS Barriers or Equipment (Associated Apparatus) must be Factory Mutual Research Approved and the configuration of Associated Apparatus must be Factory Mutual Research Approved under the Entity Concept. The Associated Apparatus may be installed within the Hazardous (Classified) location for which it is approved. The Associated Apparatus and hazardous location loop apparatus manufacturer's control drawings must be followed when installing this equipment. An AEx [ib] Associated Apparatus is suitable only for connection to Class I, Zone 1, Hazardous (Classified) Locations and is not suitable for Class I, Zone 0, or Class I, Division 1 Hazardous (Classified) Locations.
- Installation should be in accordance with ANSI/ISA RP12.6 "Installation of Intrinsically Safe Systems for Hazardous (Classified) Locations" and Article 500 of the National Electrical Code (ANSI/NFPA 70).
- All units suitable for Type 4X installations.
- The Intrinsic Safety Entity concept allows the interconnection of two FM Approved intrinsically safe devices with entity parameters not specifically examined in combination as a system when:

Ui or Vmax > Uo or Voc or Vt > 7.2 volts	<b>Entity Parameters</b>
li or Imax > lo or Isc or It	Ui (Vmax) = 30 V
Ca or Co > Ci + Ccable	li (Imax) = 125 mA
La or Lo > Li + Lcable	Pi = 0.70 watts
Pi > Po.	Ci = 0 uF
	Li = mH

6. No revision to this drawing is permitted without prior Factory Mutual Research Approval.

# 1.7 EU Declaration of Conformity



We, ControlAir LLC  
 8 Columbia Drive  
 Amherst, NH 03031

Declare that the Type 950XP Transducer family to which this declaration applies, comply with these standards:  
 EN 50082-1:1998  
 EN 55011:1999  
 EN 61010-1:1993 including AMD2:1995

Following the provisions of EMC directive 89/336/EEC  
 EN 60079-0:2012 + A11:2013  
 EN 60079-1:2014  
 EN 60079-11:2012  
 EN 60079-15:2010

Following the provisions of ATEX directive 2014/34/EU

## 2. OPERATION

### 2.1 Calibration

- 2.1.1 All units are shipped from the factory calibrated, direct acting. If the user requires a different mode of operation (i.e. reverse acting, split range) it is necessary to reposition internal electrical dip switches located on the circuit board (see figure 1 ) as indicated below in Figure 3.
- 2.1.2 Though the units are factory calibrated for direct acting operation it is suggested that the user check the calibration to ensure that settings and operation match the application requirements.

**NOTE** *ATEX option units come with a factory installed cover lock setscrew. Setscrew must be loosened before removing cover. Setscrew must be retightened upon replacing cover. See Figure 1, Section 1.4*

**NOTE** *It is not necessary to remove the plastic cover of the unit for calibration if the Direct Acting mode is desired.*

**NOTE** *Repeated cycling of supply pressure may cause increased leakage and premature product failure.*

### 2.2 Direct Acting Calibration

- 2.2.1 In direct acting operation the unit is calibrated so that minimum input signal corresponds to minimum output pressure and increasing input signal results in increasing output pressure.
- 2.2.2 Apply the minimum input signal of the range being used (e.g. 4mA for a 4-20mA unit).
- 2.2.3 Observe the output pressure. If necessary, adjust the zero screw until reaching minimum output pressure setting. Turn zero screw clockwise to decrease and counter clockwise to increase.
- 2.2.4 Apply the maximum input signal of the range being used (e.g. 20mA for a 4-20mA unit).
- 2.2.5 Observe the output pressure. If necessary, adjust the span screw until reaching maximum output pressure setting.
- 2.2.6 After setting the span it will be necessary to recheck the zero. Repeat steps 2-5 until both end points are at required values.

**Figure 3 Direct Acting Switch Settings**

SWITCH	1	2	3	4	5	6	7	8	9	10	11	12
ON												
OFF	■	■	■	■	■	■	■	■	■	■	■	■

### 2.3 Reverse Acting Calibration

- 2.3.1 When calibrating to operate in the reverse acting mode the minimum input signal produces the maximum output pressure and increasing the input signal results in decreasing the output pressure. Setting the unit to operate in the reverse acting mode is accomplished by positioning internal electrical dip switches located on the circuit board (see figure 1).

**CAUTION** *Do not touch any components on circuit board except dip switches.*

**CAUTION** *Do not reverse the input leads. Damage may occur.*

**CAUTION** *Transducer fails in direct mode regardless of operating mode selected.*

- 2.3.2 Access circuit board by first removing the die cast cover of the unit. Then remove plastic cover by taking out two screws.
- 2.3.3 Position the dip switches as illustrated in Figure 4. Replace both covers.
- 2.3.4 Set the input signal to the minimum value being used. Turn the zero screw to set the maximum output pressure. Turn screw clockwise to decrease and counter clockwise to increase.

**NOTE** *In reverse acting mode, the effect of turning the span screw is the opposite of direct acting mode.*

- 2.3.5 Set the span by applying the maximum input signal. Turn the span screw to set the minimum output pressure. Turn screw counter clockwise to decrease and clockwise to increase.
- 2.3.6 It may be necessary to repeat steps 4-5 until both end points are at desired values.
- 2.3.7 Replace both covers by reversing procedure of step 2.3.2.

**NOTE** *Switches not shown match Direct Acting Settings (see figure 3).*

**Figure 4 Reverse Acting Switch Settings**

SWITCH	3	4	5	6	7	10
ON		■		■		■
OFF	■		■		■	

## 2.4 Split Range Calibration

**NOTE** Units with field selectable option can not be split ranged.

**CAUTION** Do not touch any components on circuit board except dip switches.

- 2.4.1 When calibrated to operate in the split range mode a full input signal (i.e. 4-20mA) will operate the unit at one half the normal output span (i.e. 3-9 psig, 9-15 psig). Setting the unit to operate in the split range mode is accomplished by positioning internal electrical dip switches.
- 2.4.2 Access circuit board by first removing the die cast cover of the unit. Then remove plastic cover by taking out two screws.
- 2.4.3 Position switches as illustrated in Figure 5.
- 2.4.4 Replace both covers by reversing procedure of step 2.4.2.
- 2.4.5 After replacing covers, refer to the appropriate calibration procedure (Direct Acting or Reverse Acting) to get to desired output range (i.e. 3-9 psig, 9-15 psig).

**NOTE** Switches not shown match Direct Acting Settings (see figure 3).

**Figure 5 Split Range Switch Settings**

SWITCH	1	2
ON	■	■
OFF		

## 2.5 Field Selectable Calibration (Optional)

**NOTE** Units with field selectable option can not be split ranged.

**CAUTION** Do not touch any components on circuit board except dip switches.

- 2.5.1 Unit is shipped calibrated and labeled as ordered. Changing the unit to operate in a different range is accomplished by positioning internal dip switches.
- 2.5.2 Access circuit board by first removing the die cast cover of the unit. Then remove plastic cover by taking out two screws.
- 2.5.3 Position switches as illustrated in Figure 6 to reach desired output range.
- 2.5.4 Replace both covers by reversing procedure of step 2.5.2.
- 2.5.5 After replacing covers, refer to the appropriate calibration procedure (Direct Acting or Reverse Acting) to get to desired output range (i.e. 3-15 psig, 3-27 psig or 6-30 psig).

**NOTE** Switches not shown match Direct Acting Settings (see figure 3).

**Figure 6 Field Select Switch Settings**

<b>Field Select - High (3-27 psig and 6-30 psig)</b>		
SWITCH	1	2
ON		
OFF	■	■

<b>Field Select - Low (3-15 psig)</b>		
SWITCH	1	2
ON	■	■
OFF		

## 3. MAINTENANCE AND REPAIRS

**NOTE** Under normal circumstances, no maintenance should be required.

### 3.1 Instrument Air Filtration

- 3.1.1 Failures due to instrument supply air contamination are not covered by warranty.
- 3.1.2 Use of oil and/or water saturated instrument air can cause erratic operation.
- 3.1.3 Poor quality instrument air can result in unit failure. It is recommended that a filter regulator (such as ControlAir Type 300) be placed upstream of each unit where oil and/or water laden instrument air is suspected.
- 3.1.4 If clean, dry air is not used the orifice can become blocked. To clean, first turn off supply air, then remove the screw located on the side of the unit above the "out" port. Unplug the orifice using a wire that has a smaller diameter than 0.012" (0.30mm). Replace screw tightly into unit.

### 3.2 Factory Repairs

- 3.2.1 In the event of unit failure, the Type 950XP can be returned to the factory through point of purchase for warranty repair under the terms of ControlAir's warranty policy.
- 3.2.2 All units returned for repair must be authorized prior to receipt at the factory. Contact a representative at the point of purchase to receive a Return Authorization Number.

## 4. TROUBLESHOOTING

PROBLEM	LOOK FOR	SOLUTION
Sluggish performance	Blocked orifice	Clean external orifice (3.1.4)
Output won't go above 0	No air input	Check Instrument air supply (1.1.3)
Output stays below 3 psi with increase of input	Input leads reversed Bad electrical connection Circuit board failure	Reverse input leads (1.4.2) Check input wiring (1.4.2) Factory Repair (3.2.1)
Unit will not go full scale with full-scale input	Insufficient supply pressure Leak in connections Circuit board failure	Increase supply pressure (1.1.3) Check connections (1.3.1) Factory Repair (3.2.1)

**NOTE** If problems are not solved by troubleshooting procedures, contact a factory applications engineer at 603-886-9400 for further assistance.

## 5. WARRANTY & DISCLAIMER

ControlAir LLC products are warranted to be free from defects in materials and workmanship for a period of eighteen months from the date of sale, provided said products are used according to ControlAir LLC recommended usages. ControlAir LLC's liability is limited to the repair, purchase price refund, or replacement in kind, at ControlAir LLC's sole option, of any products proved defective. ControlAir LLC reserves the right to discontinue manufacture of any products or change products materials, designs or specifications without notice.

**WARNING** Unless otherwise specified, these products are intended for use in industrial compressed-air systems only. Do not use these products where pressures and temperatures can exceed those listed under Specifications.

Before using these products with fluids other than air, for non-industrial application, life-support systems, or other applications not within published specifications, consult ControlAir LLC.



8 Columbia Drive / Amherst, NH 03031 USA  
Website: [www.controlair.com](http://www.controlair.com)  
Email: [sales@controlair.com](mailto:sales@controlair.com)  
603-886-9400 FAX 603-889-1844

An ISO-9001:2008 Certified Company