



Installation, Operation and Maintenance Instructions

TYPE 715BP Signal Operated Precision Back Pressure Regulator

The Type 715BP Signal Operated Back Pressure Regulator is a 1:1 signal to output ratio regulator that is high flow and a highly accurate relief valve. It is a normally closed valve that will remain closed until the upstream pressure at the inlet exceeds the signal pressure. When upstream pressure does exceed the signal pressure, the valve will open and flow air until upstream pressure decreases to below the signal pressure. It can also be used as a flow controller. Varying the signal pressure, usually with an I/P transducer, will increase or decrease the amount of air allowed to flow from upstream to downstream.

1. SPECIFICATIONS

Functional Specifications

Flow Capacity	Up to 90 SCFM (2,548 NL/min)
Cv	1/4 NPT: 1.5; 3/8 NPT and 1/2 NPT: 2.0
Maximum System Pressure	250 psig (17.25 bar)
Maximum Signal Pressure	150 psig (10 bar)
Ambient Temperature	0° to 150° F (-18° to 66° C)
Sensitivity	1/4" (6.4 mm water)
Ratio Accuracy	1.0% of a 100 psig (7.0 bar) signal span

Physical Specifications

Materials of Construction	Body: diecast aluminum alloy, baked enamel finish Trim: acetal, brass, and plated steel
Weight	1.20 lbs. (0.54 kg)
Port Sizing	Inlet/Outlet: 1/4", 3/8, or 1/2" NPT/BSPP Gauge (2): 1/4" NPT/BSPP

2. DIMENSIONAL DRAWING

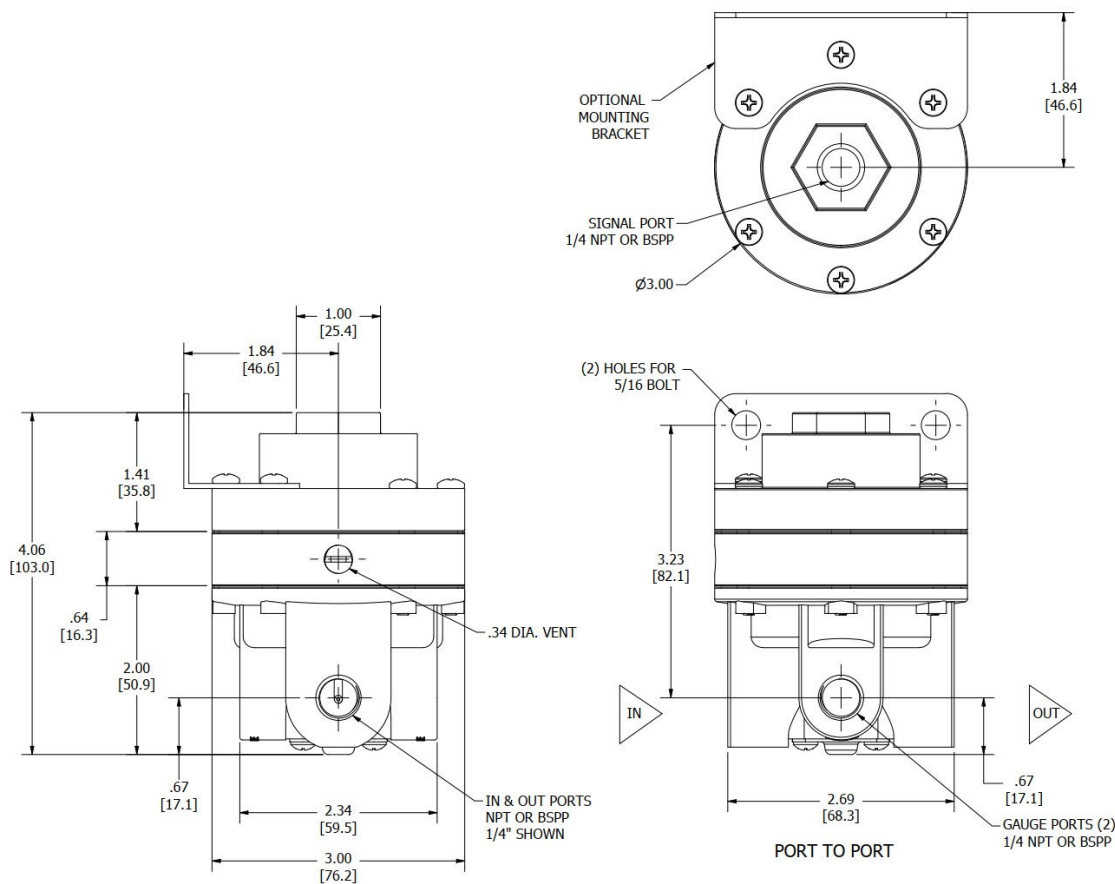

(Drawing downloads available at <http://www.controlair.com>)

3. INSTALLATION



WARNING: Only qualified personnel should install or service a regulator. Regulators should be installed, operated, and maintained in accordance with international and applicable codes and regulations, and ControlAir instructions. If the regulator vents fluid or a leak develops in the system, it indicates that service is required. Failure to take the regulator out of service immediately may create a hazardous condition. Personal injury, equipment damage, or leakage due to escaping fluid or bursting of pressure-containing parts may result if this regulator is over pressured or is installed where service conditions could exceed the limits given in the Specifications section, or where conditions exceed any rating of the adjacent piping or piping connections. To avoid such injury or damage, provide pressure-relieving or pressure-limiting devices (as required by the appropriate code, regulation, or standard) to prevent service conditions from exceeding limits. Additionally, physical damage to the regulator could result in personal injury and property damage due to escaping fluid. To avoid such injury and damage, install the regulator in a safe location.

3.1 Pre-Installation Requirements

- 3.1.1 The Type 715BP requires a source of clean, oil-free dry instrument grade air filtered to 40 microns.
- 3.1.2 Air should be free of all contaminants and hazardous gases, flammable or toxic.
- 3.1.3 Clean all pipelines of dirt and scale prior to installation.

NOTE

Failures attributable to instrument air supply contamination are not covered by the warranty.

CAUTION

This instrument vents to atmosphere. The use of supply gas other than air can create a hazardous environment.

3.1.4 Apply a minimum amount of pipe compound to the male threads of the fitting only. Do not use thread sealant tape on pipe fittings as it tends to contaminate the valve causing the regulator to malfunction.

3.2 Installation

3.2.1 Install the regulator so that direction of flow is from Inlet to Outlet as labeled "IN" and "OUT" marked on the body. Inlet and outlet porting is 1/4", 3/8" or 1/2" NPT. Tighten all connections securely.

3.2.2 Regulator can be mounted in any position and is typically pipe-mounted between the pneumatic supply source and the actuator.

NOTE

Avoid undersized fittings that will limit flow through the regulator and cause pressure drop downstream.

NOTE

The use of a filter regulator to remove dirt and liquid in the air line ahead of the regulator is recommended for best performance.

NOTE

If an air lubricator is used, it should be located downstream beyond the regulator in order to avoid interference with the regulator performance.

3.2.3 Ensure that piping to and from the regulator is of proper size to meet the capacity demands of the system.

4. OPERATION

Apply a signal pressure to the signal port. Apply a supply pressure to the IN port. When the supply pressure exceeds the signal pressure, the internal valve will open, and air will flow to the OUT port. Increasing the signal pressure above and below the pressure at the IN port will open and close the internal valve.

Over Pressurization Protection

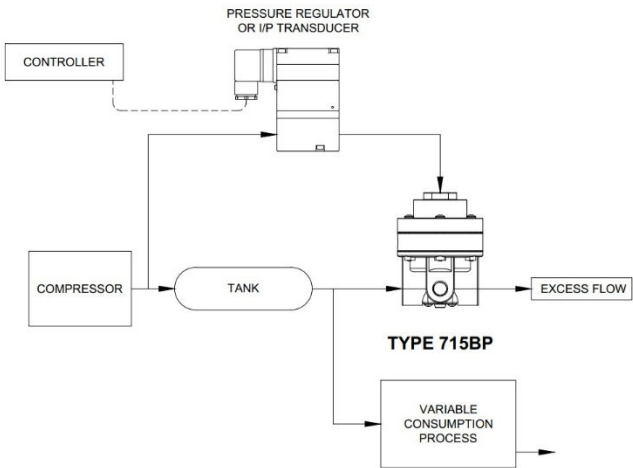

Flow Controller

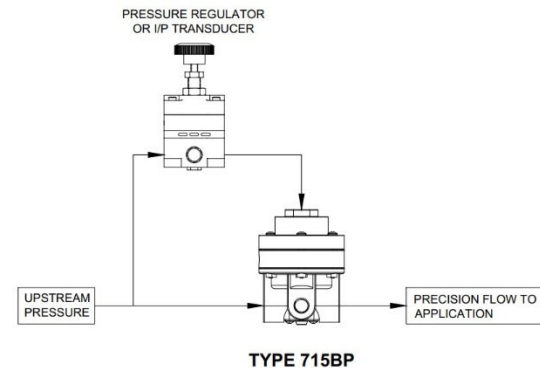

5. MAINTENANCE AND REPAIRS

NOTE

Under normal circumstances, no maintenance should be required.

5.1 Repairs

- 5.1.1 In the event of unit failure, the Type 715BP can be returned to the factory through point of purchase for warranty repair if the warranty period has not expired.
- 5.1.2 All units returned for repair must be authorized prior to receipt at the factory. Contact a representative at the point of purchase to receive a Return Authorization Number
- 5.1.3 Repair kit for the Type 715BP is available.
Repair Kit includes: * Items
Contact factory to order.

Repair Kit P/N: 449-871-261

TYPE 715 PARTS LIST		
ITEM	QTY	DESCRIPTION
1	1	DIAPHRAGM ASSEMBLY
2	1	SPRING
3*	1	SPRING GUIDE
4	1	BONNET ASSEMBLY
5	8	10-32 x 7/8 SCREWS & WASHERS
6*	1	KNOB ASSEMBLY
7*	1	BODY ASSEMBLY
8	1	O-RING

*INCLUDED IN REPAIR KIT

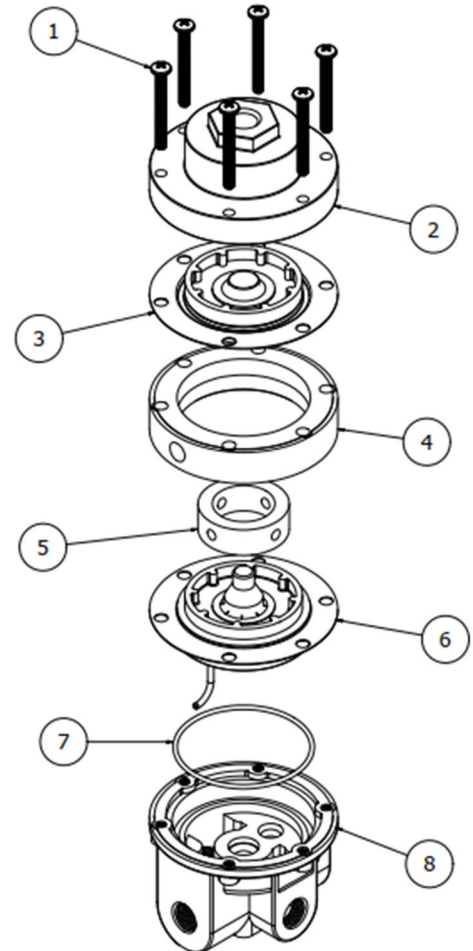

6. WARRANTY & DISCLAIMER

ControlAir LLC products are warranted to be free from defects in materials and workmanship for a period of eighteen months from the date of sale, provided said products are used according to ControlAir LLC recommended usages. ControlAir LLC's liability is limited to the repair, purchase price refund, or replacement in kind, at ControlAir LLC's sole option, of any products proved defective. ControlAir LLC reserves the right to discontinue manufacture of any products or change products materials, designs or specifications without notice. Note: ControlAir does not assume responsibility for the selection, use, or maintenance of any product. Responsibility for the proper selection, use, and maintenance of any ControlAir product remains solely with the purchaser and end user.

WARNING

These products are intended for use in industrial compressed-air systems only. Do not use these products where pressures and temperatures can exceed those listed under Specification

8 Columbia Drive, Amherst, New Hampshire 03031 U.S.A.
Tel: (603) 886-9400 ♦ Fax: (603) 889-1844
www.controlair.com