



Type 7100

Precision Air Pressure Regulator

Superior accuracy and stability with high forward and reverse flow capacity

The Type 7100 is a high precision, multi-stage pressure regulator offering fine adjustment and maximum stability under variable operating conditions. The Type 7100 combines the proven and reliable technology of the ControlAir Type 100 with the high forward and reverse flow of the Type 6100, 1:1 Relay Volume Booster. A highly sensitive capsule controls the pilot pressure which offers crisp and accurate adjustment, superior to conventional spring operated regulators.

Features

- **1/4", 1/2" or 3/4" NPT Porting**
- **Two 1/4" NPT Gauge Ports**
- **Adjustment Control**
Standard tension nut prevents inadvertent pressure adjustment.
- **High Flow Capacity**
See flow curves.
- **Superior Sensitivity**
Senses output pressure deviations to within 1/4 inch water column pressure.
- **Stable output**
Isolated control chamber prevents output variation and vibration during flow conditions.
- **Balanced Supply Valve**
Virtually eliminates output pressure changes due to supply pressure variations.



Regulated Pressure vs Flow: 1/4" Type 7100

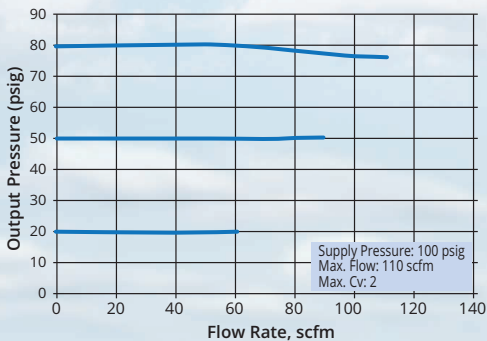

Regulated Pressure vs Flow: 1/2" Type 7100

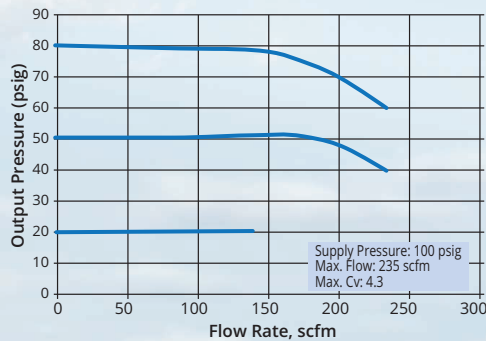

Regulated Pressure vs Flow: 3/4" Type 7100

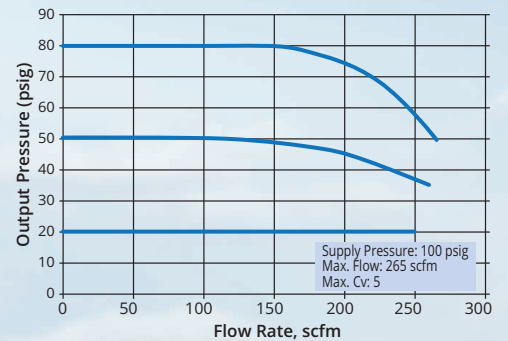

Type 7100 Precision Air Pressure Regulator

Dimensions

inch
[mm]

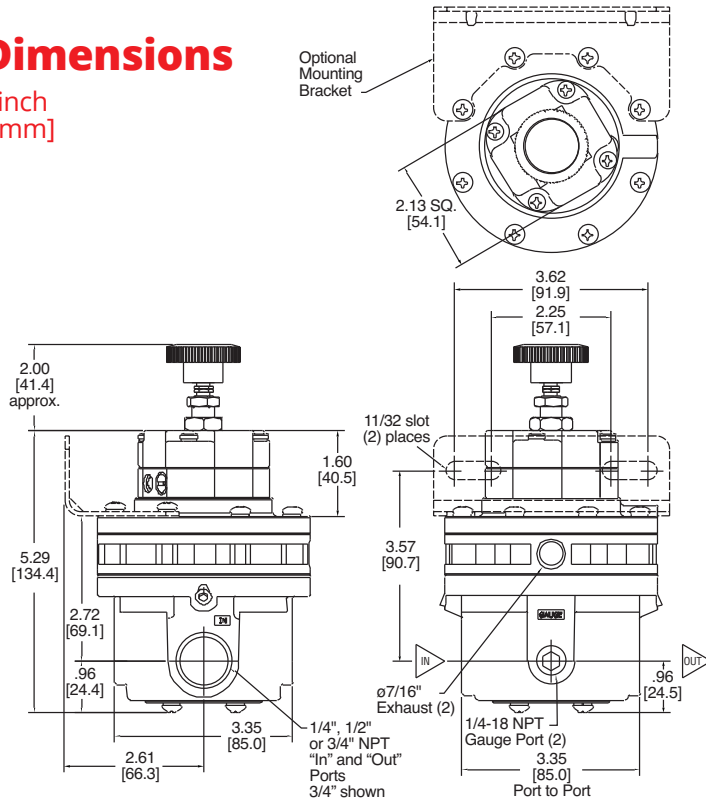

Specifications

Supply Pressure	250 psig (17.0 bar) maximum		
Air Consumption	14 scfh (6.6 NL/min)		
Temperature Limits	-20 to 160 °F (-29 to 71 °C)		
Maximum Flow Coefficients (Cv)	Port	Forward	Exhaust
	3/4"	5.0	3.5
	1/2"	4.5	3.5
	1/4"	2.0	2.5
Exhaust Capacity	3/4"	80 scfm (2,264 NL/min)	
	1/2"	75 scfm (2,123 NL/min)	
	1/4"	35 scfm (991 NL/min)	
Sensitivity	Less than 1/4 inch (6.3 mm) water		
Effect of Supply Pressure Variation on Output	.05 psig (3.4m bar) for a 100 psig (6.9 bar) change		
Mounting	Pipe, panel or bracket		
Supply/Output Port	1/4", 1/2", or 3/4" NPT		
Exhaust Port (2)	ø7/16" or 1/4" NPT option		
Gauge Port (2)	1/4" NPT		
Weight	2.5 lbs (1.13 kg)		

Materials

Housing	Diecast aluminum alloy and zinc alloy
Bolting	Zinc Plated Steel
Knob	Phenolic plastic
Internal components	Stainless steel, plated steel, brass, aluminum
Elastomers	Nitrile

Principles of Operation

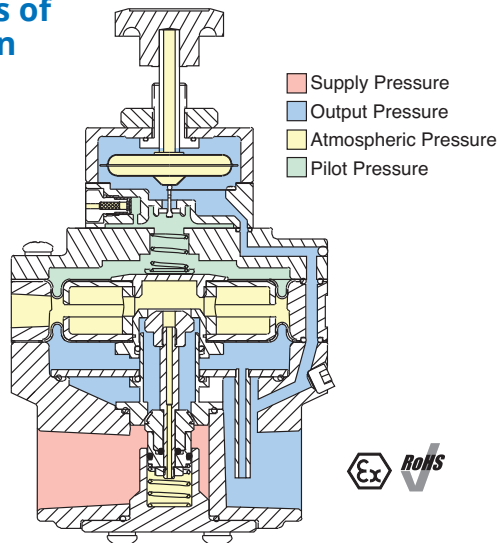

Warranty ControlAir LLC products are warranted to be free from defects in materials and workmanship for a period of eighteen months from the date of sale, provided said products are used according to ControlAir LLC recommended usages. ControlAir LLC's liability is limited to the repair, purchase price refund, or replacement in kind, at ControlAir LLC's sole option, of any products proved defective. ControlAir LLC reserves the right to discontinue manufacture of any products or change products materials, designs or specifications without notice. Note: ControlAir does not assume responsibility for the selection, use, or maintenance of any product. Responsibility for the proper selection, use, and maintenance of any ControlAir product remains solely with the purchaser and end user. Drawing downloads available at www.controlair.com

Ordering Use this coding system to order

Model

7100

Port Size (NPT)

B 1/4"
D 1/2"
E 3/4"

Range

A 2-40 psig (0.14-2.7 bar)
B 2-60 psig (0.14-4.1 bar)
C 2-120 psig (0.14-8.2 bar)

Options

E Tapped Exhaust: allows captured exhaust from the (2) 1/4" NPT spacer ports and barbed bleed screw
T Tamper-proof Cover: prevents casual adjustment of output pressure
X ATEX 2014/34/EU

Accessories

Mounting Bracket (zinc plated steel): P/N 449-542-045

1/4" NPT Exhaust Screen/Muffler Fitting:

Plated Steel: P/N 445-761-008

(Unit must have 'E' tapped exhaust option)

ControlAir

8 Columbia Drive / Amherst, NH 03031 USA / www.controlair.com
sales@controlair.com / 603-886-9400 / FAX 603-889-1844

An ISO 9001:2015 Registered Company



P/N 441-625-071 6/9/26