



Type 6500/6600

Large Flow Capacity Volume Booster

Rapid Stroke Capability in a Rugged Aluminum or Stainless Steel Casing



The ControlAir Type-6500 aluminum and Type-6600 stainless steel volume boosters are 1:1 signal to output relays that are utilized in applications that require high flow capacity. Typically they are used to increase throttling speed of large volume valve actuators. They are suitable for either diaphragm or piston actuators. A fixed deadband and adjustable bypass valve combine to allow small incremental downstream adjustment without opening the main booster valve. The bypass valve is used to adjust dynamic response to provide stable operation over a wide range of actuator sizes.

Features

- **316 Stainless Steel Construction**
- **3/4" or 1" NPT Porting**
- **Integral Adjustable Bypass Valve**
Allows small incremental signal changes without opening the primary valve
- **High Flow Capacity**
For rapid actuator stroking
- **Soft Valve Seat Design** Provides tight shutoff and eliminates leakage in steady state operation
- **High Temperature Operation**
Up to 200°F (93°C)
- **Tapped High Output Exhaust Port**
3/4" NPT exhaust port relieves 100 scfm (2,830 NL/min)
- **(2) 1/4" Gauge Ports**
- **Optional Feedback Port**
- **Low Temperature Option** Silicone elastomers allow use to -62°F (-52°C)
- **IEC 61508 SIL 3 Certified**

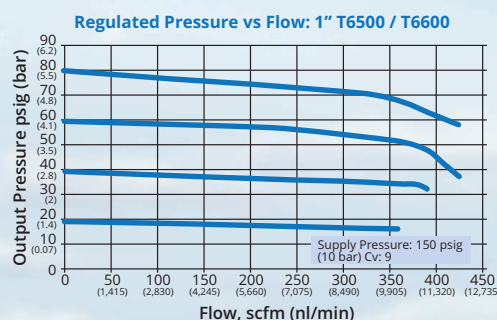
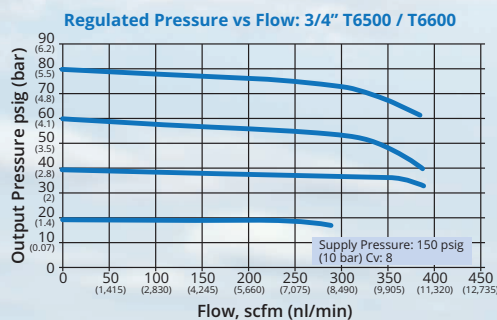

Type 6500/6600 Large Flow Capacity Volume Booster

Dimensions

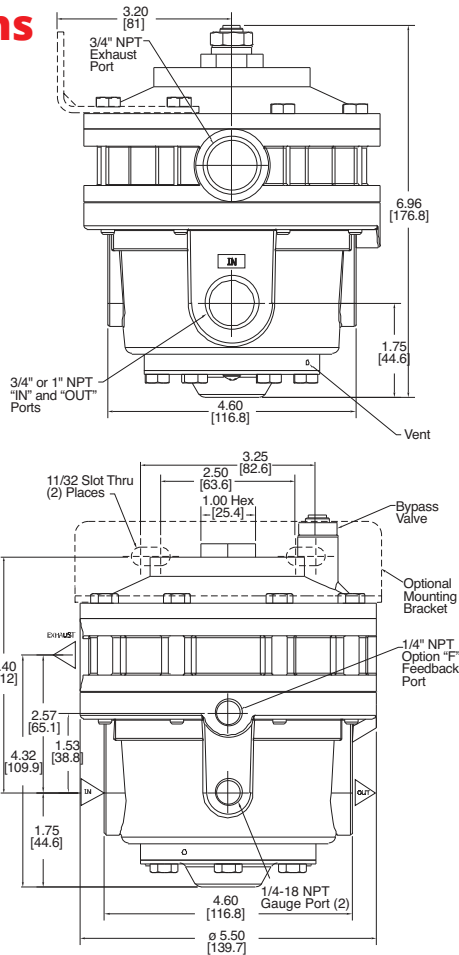

Principles of Operation

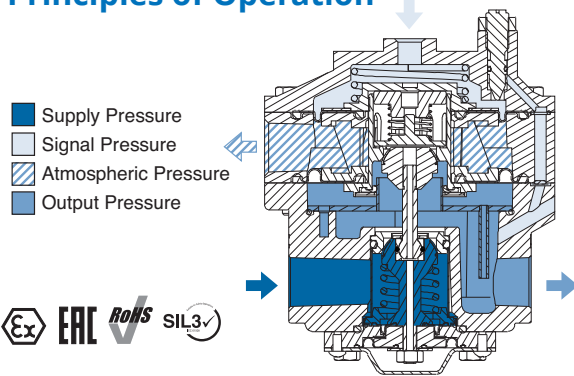

Warranty ControlAir LLC products are warranted to be free from defects in materials and workmanship for a period of eighteen months from the date of sale, provided said products are used according to ControlAir LLC recommended usages. ControlAir LLC's liability is limited to the repair, purchase price refund, or replacement in kind, at ControlAir LLC's sole option, of any products proved defective. ControlAir LLC reserves the right to discontinue manufacture of any products or change products materials, designs or specifications without notice. Note: ControlAir does not assume responsibility for the selection, use, or maintenance of any product. Responsibility for the proper selection, use, and maintenance of any ControlAir product remains solely with the purchaser and end user. Drawing downloads available at www.controlair.com

Specifications

Signal/Output Ratio	1:1		
Supply Pressure	250 psig (17.0 BAR) Maximum		
Signal Pressure	150 psig (10.0 BAR) Maximum		
Temperature Limits	-40 to 200 °F (-40 to 93 °C) Low temperature option -62 to 194 °F (-52 to 90 °C)		
Maximum Flow Coefficients (Cv)		Forward	Exhaust
	3/4"	8.0	8.0
	1"	9.0	8.0
Exhaust Capacity	5 psig (0.35 BAR) above a 20 psig (1.37 BAR) setpoint		
	3/4"	150 scfm (4,245 NL/min)	
	1"	150 scfm (4,245 NL/min)	
Output Accuracy	2.0% of span		
Deadband	Under 0.2 psig (.01 BAR)		
Supply Pressure Effect	0.3 psig (0.02 BAR) for a 100 psig (7 BAR) change		
Signal Port	1/4" NPT, 1/4" BSP*		
Supply/Output Port	3/4" or 1" NPT, 1" BSP*		
Exhaust Port	3/4" NPT, 3/4" BSP*		
Gauge Port (2)	1/4" NPT, 1/4" BSP*		
Feedback Port (Option)	1/4" NPT, 1/4" BSP*		
Weight	Type 6500 Aluminum	6.5 lbs (2.95 kg)	
	Type 6600 Stainless Steel	15.0 lbs (6.80 kg)	

*"U" (option) - All BSP porting for 1" ported units.

Materials

Materials	Type 6500	Type 6600
Housing	Aluminum	316 Stainless Steel
Bolting	Zinc Plated Steel	316 Stainless Steel
Other trim	Aluminum	316 Stainless Steel
Internal components	Aluminum	Stainless Steel
Elastomers	Nitrile	Nitrile
Low Temperature Option:	Silicone	Silicone

Ordering

Part Number	Porting	Housing Material
6500-EA	3/4" NPT	Aluminum
6500-FA	1" NPT	Aluminum
6600-ES	3/4" NPT	316 Stainless Steel
6600-FS	1" NPT	316 Stainless Steel

Options Add proper letter at end of model number.

- F Feedback Port
- L Low Temperature Operation
- R EAC TR-CU 010/2010; EAC 012/2010
- S Stainless Steel Trim (Type-6500 only)
- U BSP Porting (available for 1" ported units only)
- X ATEX 2014/34/EU

Accessories

Mounting Bracket (zinc plated steel): P/N 449-542-040

Mounting Bracket (316 stainless steel): P/N 449-542-041

3/4" NPT Exhaust Screen/Muffler Fitting:

Plated Steel: P/N 445-761-006 316 Stainless Steel: P/N 445-761-007

Gauges (1/4" NPT, 2" dual scale, back mount):

Type 6500: Range - 0-160 psi (0-11 BAR) P/N 446-725-002

Type 6600 (stainless steel): Range - 0-160 psi (0-11 BAR) P/N 445-725-021



8 Columbia Drive / Amherst, NH 03031 USA / www.controlair.com / sales@controlair.com / 603-886-9400 / FAX 603-889-1844

An ISO 9001:2015 Registered Company

P/N 441-625-064 4/3/23