



Type 6100/6200

High Flow Capacity Volume Booster

Rapid stroke capability in rugged aluminum or 316 stainless steel construction

The ControlAir Type 6100/6200 volume booster is a 1:1 signal to output relay that is utilized in applications that require high forward flow and exhaust capacities. The Type 6100 is constructed of aluminum and the Type 6200 is constructed of 316 stainless steel. Typically they are used to increase throttling speed of large volume valve actuators. They are suitable for either diaphragm or piston actuators. A fixed deadband and adjustable bypass valve combine to allow small incremental downstream adjustment without opening the main booster valve. The bypass valve is used to adjust dynamic response to provide stable operation over a wide range of actuator sizes.



Features

- **1/4", 1/2" or 3/4" NPT Porting**
- **Aluminum or 316 Stainless Steel Construction**
- **Integral Adjustable Bypass Valve**
Allows small incremental signal changes without opening the primary valve
- **High Flow Capacity**
For rapid actuator stroking
- **Soft Valve Seat Design** Provides tight shutoff and eliminates leakage in steady state operation
- **High Temperature Operation**
Up to 200°F (93°C), Optional 284°F (140°C)
- **Low Temperature Operation**
-62° to 194°F (-52° to 90°C)
- **Expanded Temperature Operation**
-55° to 284°F (-48° to 140°C)
- **High Output Exhaust Vents**
(2) 1/4" NPT tapped exhaust (Type 6100 option)
1/2" NPT tapped exhaust (Type 6200 standard)
- **(2) 1/4" NPT Gauge Ports**
- **Optional Negative Bias**
4 psi (0.3 bar) negative bias of signal pressure to 'zero' I/P's
- **IEC 61508 SIL3 Certified**

Regulated Pressure vs Flow: 1/4" Type 6100/6200

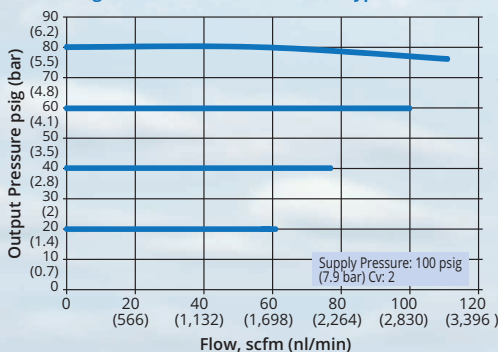

Regulated Pressure vs Flow: 1/2" Type 6100/6200

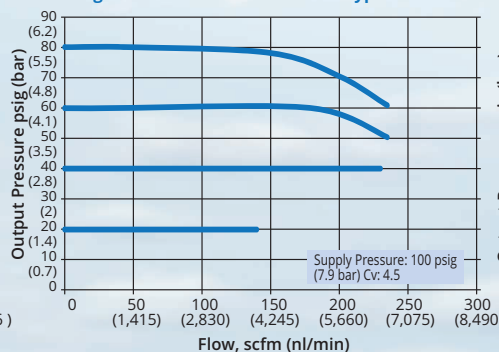

Regulated Pressure vs Flow: 3/4" Type 6100/6200

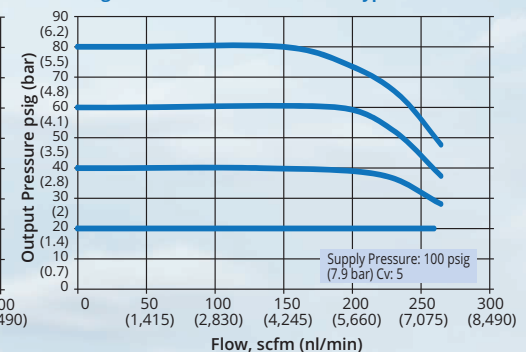

Type 6100/6200 High Flow Capacity Volume Booster

Dimensions

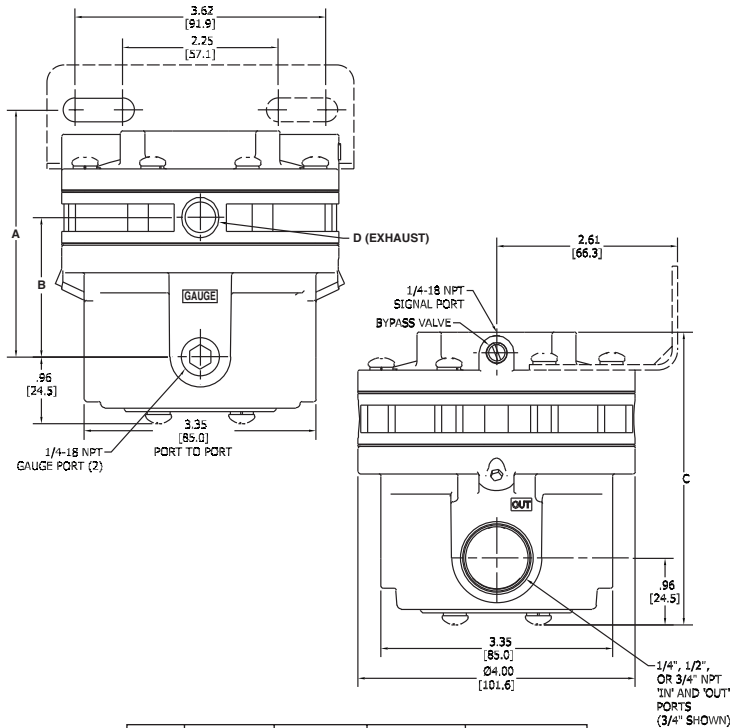

Principles of Operation

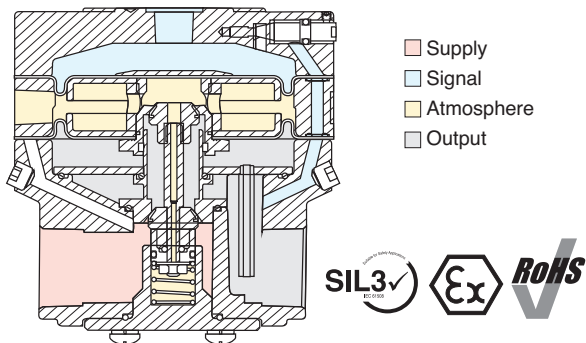

Warranty ControlAir LLC products are warranted to be free from defects in materials and workmanship for a period of eighteen months from the date of sale, provided said products are used according to ControlAir LLC recommended usages. ControlAir LLC's liability is limited to the repair, purchase price refund, or replacement in kind, at ControlAir LLC's sole option, of any products proved defective. ControlAir LLC reserves the right to discontinue manufacture of any products or change products materials, designs or specifications without notice. Note: ControlAir does not assume responsibility for the selection, use, or maintenance of any product. Responsibility for the proper selection, use, and maintenance of any ControlAir product remains solely with the purchaser and end user. Drawing downloads available at www.controlair.com

Specifications

Signal/Output Ratio	1:1			
Supply Pressure	250 psig (17.0 bar) Maximum			
Signal Pressure	150 psig (10.0 bar) Maximum			
Temperature Limits	-40 to 200 °F (-40 to 93 °C)			
Low Temperature Option	-62 to 194 °F (-52 to 90 °C)			
Expanded Temperature Option	-55 to 284 °F (-48 to 140 °C)			
Maximum Flow Coefficients (Cv)	Port	Forward	6100 Exhaust	6200 Exhaust
	3/4"	5.0	3.5	4.0
	1/2"	4.5	3.5	4.0
	1/4"	2.0	2.5	3.0
Exhaust Capacity	3/4"	80 scfm (2,264 NL/min)		
5 psig (0.35 bar) above	1/2"	75 scfm (2,123 NL/min)		
20 psig (1.38 bar) setpoint	1/4"	35 scfm (991 NL/min)		
Output Accuracy	1.0% of 100 psi output span			
Sensitivity	1" H ₂ O (2.54 cm)			
Deadband	Under 0.2 psig (.01 bar)			
Supply Pressure Effect	0.1 psig (.007 bar) for a 25 psig (1.7 bar) change			
Signal Port	1/4" NPT			
Supply/Output Port	1/4", 1/2", or 3/4" NPT			
Exhaust Port	Type 6100: ø7/16" or 1/4" NPT option Type 6200: 1/2" NPT			
Gauge Port (2)	1/4" NPT			
Weight	Type 6100: 2.5 lbs (1.13 kg) Type 6200: 5.7 lbs (2.60 kg)			

Materials

	Type 6100	Type 6200
Housing	Aluminum	316 Stainless Steel
Bolting	Zinc Plated Steel	Stainless Steel
Other trim	Aluminum	Stainless Steel
Internal components	Aluminum	Stainless Steel
Elastomers	Nitrile	Nitrile
Low Temperature Option	Silicone	Silicone
Expanded Temperature Option	EPDM	EPDM

Ordering

Part Number	Housing Material	Porting
6100-BA	Aluminum	1/4" NPT
6100-DA	Aluminum	1/2" NPT
6100-EA	Aluminum	3/4" NPT
6200-BS	316 Stainless Steel	1/4" NPT
6200-DS	316 Stainless Steel	1/2" NPT
6200-ES	316 Stainless Steel	3/4" NPT

Options Add proper letter at end of model number.

- E** (2) 1/4" NPT Tapped Exhaust Vents (Type 6100 only)
- L** Low Temperature: -62 to 194 °F (-52 to 90 °C)
- P** Expanded Temperature: -55 to 284 °F (-48 to 140 °C)
- S** Stainless Steel Trim (Type 6100 only)
- X** ATEX 2014/34/EU
- Z** Negative Bias -4 +/-1 psi bias

Accessories

Mounting Bracket (zinc plated steel): P/N 449-542-045

Mounting Bracket (stainless steel): P/N 449-542-050

Exhaust Screen/Muffler Fitting:

Type 6100 - 1/4" NPT Plated Steel: P/N 445-761-008 ("E" option only)

Type 6200 - 1/2" NPT Stainless Steel: P/N 445-761-012



8 Columbia Drive / Amherst, NH 03031 USA / www.controlair.com
sales@controlair.com / 603-886-9400 / FAX 603-889-1844

An ISO 9001:2015 Registered Company

