

Type 350/360/370SS Series

Stainless Steel Regulators Installation, Operation and Maintenance Instructions

Type 350SS 1/2" NPT

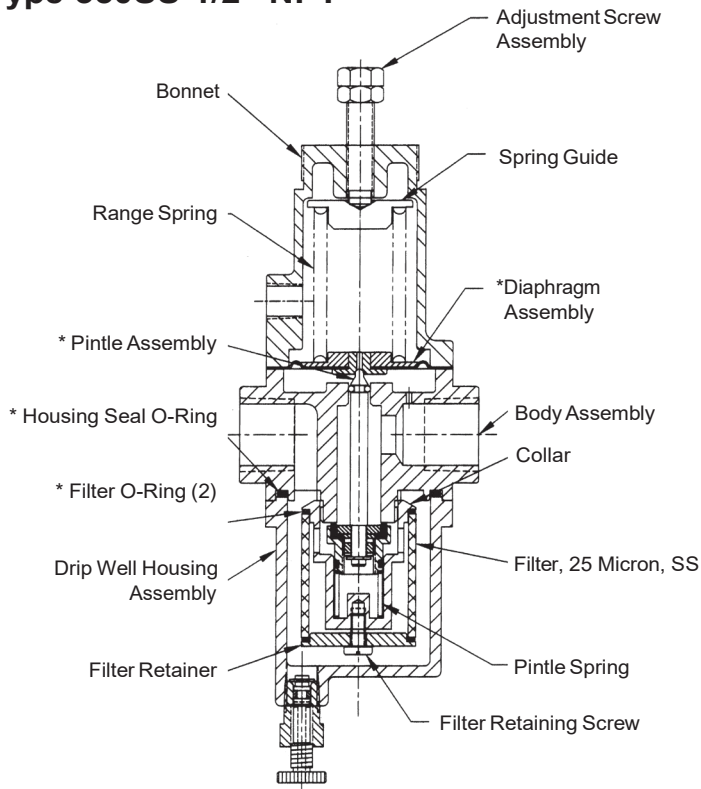

Type 360SS 1/4" NPT

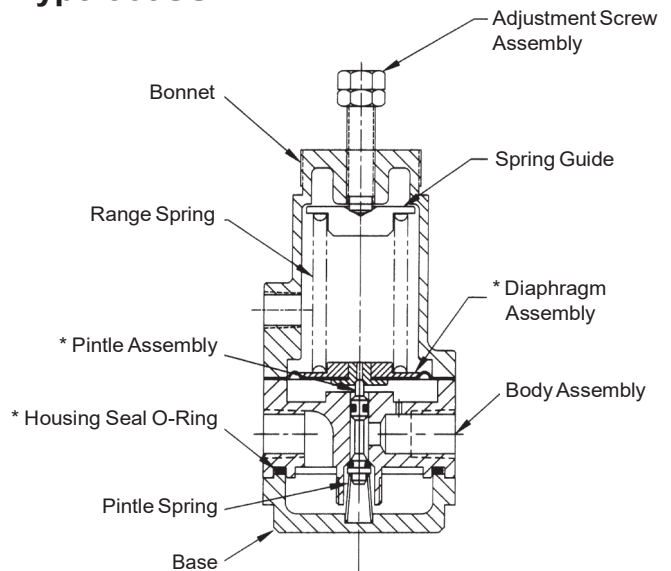

Type 370SS 1/2" NPT

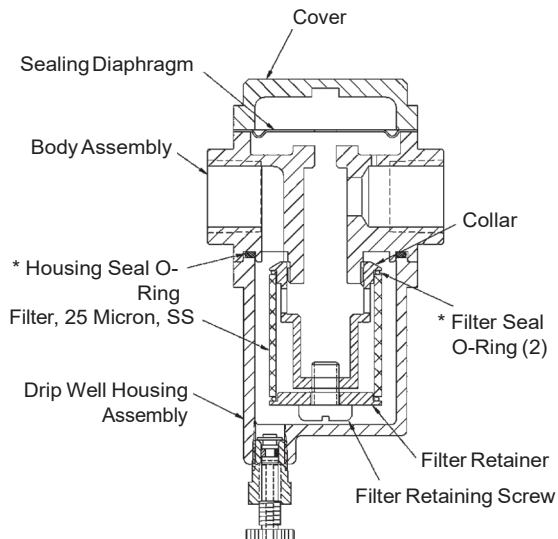

Contents

Section	Description	Page
1.0	Specifications	2
2.0	Installation	2
3.0	Operation	3
4.0	Maintenance & Repair	3
5.0	Warranty	4



8 Columbia Drive
Amherst, NH 03031 USA
603-886-9400
Fax: 603-889-1844
www.controlair.com
sales@controlair.com

*Included with repair kit

DANGER, WARNING, CAUTION and NOTE statements

DANGER Refers to conditions or hazards which could result in serious personal injury or death.

WARNING Refers to conditions or hazards which could result in personal injury.

CAUTION Refers to conditions or hazards which could result in equipment or property damage.

NOTE Alerts you to facts or special instructions.

ALL DANGER, WARNING, AND CAUTION NOTICES MUST BE COMPLIED WITH IN FULL

DANGER Personal injury, property damage, equipment damage, or leakage due to escaping gas or bursting of pressure containing parts may result if this regulator is over pressurized or installed where service conditions could exceed the limits given in the specifications. To avoid such injury or damage, provide pressure-relieving or limiting devices (as required by the appropriate code, regulation or standard) to prevent service conditions from exceeding those limits.

1. SPECIFICATIONS

	TYPE 350SS	TYPE 360SS	TYPE 370SS
Output Ranges:	0-30 psig (0-2.0 BAR), 0-60 psig (0-4.0 BAR), 0-100 psig (0-7.0 BAR), 0-150 psig (0-10.0 BAR)		Not applicable
Exhaust Capacity:	1.0 SCFM (1.7 m ³ /hr) at downstream pressure of 10 psig (0.7 BAR) above set point		Not applicable
Maximum Supply Pressure:	290 psig (20.0 BAR)		150 psig (10.0 BAR)
Maximum Flow Coefficients (Cv):	1/4" = 1.2 1/2" = 3.3		
Air Consumption:	4 SCFH (0.1 m ³ /hr)		Not applicable
Operating Temperatures:	-20° to +185° F (-29° to +85° C) Autodrain Option: (Type-350 and Type-370 only) 32° to 185°F (0° to 85°C) Low Temperature Option: -58° to +194° F (-50° to +90° C)		
Filter:	25 micron optional 5 micron filter	Not applicable	25 micron optional 5 micron filter
Porting:	Inlet/Outlet: 1/4" NPT or 1/2" NPT Gauge (2): 1/4" NPT Exhaust: 1/8" NPT	1/4" NPT 1/4" NPT 1/8" NPT	1/4" NPT or 1/2" NPT 1/4" NPT
Materials:	316 stainless steel: body, bonnet, filter, range spring, pintle spring Fluorocarbon: diaphragm, seals Silicone: diaphragm, seals (low temperature option)		
Weight:	1/4" NPT: 2.2 lbs. (1.0 kg) 1/2" NPT: 2.8 lbs. (1.3 kg)	1/4" NPT: 2.0 lbs. (0.9 kg) Not applicable	1/4" NPT: 2.1 lbs (0.95 kg) 1/2" NPT: 2.5 lbs (1.14 kg)
Operating Media:	Air, inert gas, sweet (natural) and sour gases		

2. INSTALLATION

2.1 Install the regulator/filter as close as possible to the instrument or tool it is to service.

2.2 Clean all pipelines to remove dirt and scale prior to installation.

NOTE Failures attributable to air supply contamination are not covered by the warranty.

WARNING This instrument vents to atmosphere. The use of gas other than air may create a hazardous environment.

2.3 Install the regulator/filter so that the direction of flow is from the "IN" to "OUT" connection as marked on the body of the regulator/filter.

- 2.4 For best drainage, orient the drain valve so that it is at the lowest point on the drip well housing. Positioning of the drain valve may be improved by rotating the drip well with respect to the body.
- 2.5 The exhaust port should be kept free and unplugged. Position the regulator so that the vent is at the lowest point possible or provide additional protection to prevent contaminants from entering the regulator. Rotating the bonnet relative to the body may change the vent hole orientation.

WARNING *The Type 350/360SS has a low capacity internal relief that provides limited down-stream protection against over pressurization.*

WARNING *Non-relieving version does not provide internal relief of excess pressure. To avoid exceeding outlet pressure limits, a pressure-limiting device should be used.*

- 2.6 Exhaust may be remotely vented by installing tubing to the 1/8" NPT port.
- 2.7 Apply pipe compound or sealing tape to the male pipe threads prior to installing regulator/filter. Use caution to prevent the sealant from getting inside the regulator/filter.

3. OPERATION

- 3.1 Prior to turning on supply air, back off adjusting screw until there is no compression of the range spring.
- 3.2 After applying the air supply, output pressure will be increased by rotating the adjustment screw clockwise. Pressure can be decreased by turning counter-clockwise.
- 3.3 Tighten locknut to maintain desired pressure setting.

4. MAINTENANCE & REPAIR

- 4.1 To remove condensate from the Type 350 and Type 370, slowly open drain valve by turning clockwise and bleed accumulated liquid.

DANGER *To avoid personal injury, property damage, or equipment damage caused by sudden release of pressure or explosion of accumulated gas, do not attempt any maintenance or disassembly without first isolating the regulator from system pressure and relieving all internal pressure from the regulator.*

4.2 To clean filter element (Type 350 and Type 370)

- 4.2.1 Shut off supply pressure and relieve all internal pressure.
- 4.2.2 Drain condensate from drip well.
- 4.2.3 Remove four corner bolts from bottom of unit and remove drip well housing.
- 4.2.4 Remove filter retaining screw.
- 4.2.5 Remove filter retainer, filter o-ring seals and filter.
- 4.2.6 Clean parts and reassemble in reverse order.

4.3 To clean/replace pintle assembly

- 4.3.1 Follow steps 4.2.1 through 4.2.4.
- 4.3.2 Unscrew collar and remove.
- 4.3.3 Remove pintle spring and pintle. 1/4" NPT version may require needle nose pliers or push pintle stem from above by removing bonnet and diaphragm assembly.
- 4.3.4 Clean/replace parts and reassemble in reverse order.

4.4 To clean/replace diaphragm assembly

- 4.4.1 Back out the adjusting screw until the spring is no longer compressed.
- 4.4.2 Remove the four bonnet screws and separate the bonnet from the body of the regulator. Remove the spring guide and spring.
- 4.4.3 Remove the diaphragm assembly, clean or replace it as necessary and reassemble in reverse order. After placing the diaphragm assembly on the body, push down the assembly to make sure that the pintle is seated properly and strokes smoothly.

4.5 Repair kits/replacement parts

- 4.5.1 Repair kits include all parts marked with an asterisk (*). See diagrams on page 1.
- 4.5.2 When ordering repair kits or replacement filters, order as:

REPAIR KITS

Type 350 Includes: Pintle Assembly, Housing Seal O-Ring, Diaphragm Assembly, Filter Seal O-Ring (2)

Model	Porting	Description	Part Number
Type 350	1/4" NPT	Relieving	449-871-068
Type 350	1/4" NPT	Non-relieving	449-871-069
Type 350	1/2" NPT	Relieving	449-871-070
Type 350	1/2" NPT	Non-relieving	449-871-071

Type 360 Includes: Pintle Assembly, Housing Seal O-Ring, Diaphragm Assembly

Model	Porting	Description	Part Number
Type 360	1/4" NPT	Relieving	449-871-072
Type 360	1/4" NPT	Non-relieving	449-871-073
Type 360	1/2" NPT	Relieving	449-871-094
Type 360	1/2" NPT	Non-relieving	449-871-095

REPLACEMENT FILTERS

Model	Porting	Description	Part Number
Type 350/370	1/4" NPT	25 micron filter	446-777-019
Type 350/370	1/4" NPT	5 micron filter	446-777-012
Type 350/370	1/2" NPT	25 micron filter	446-777-020
Type 350/370	1/2" NPT	5 micron filter	446-777-014

- 4.5.3 Other replacement parts are available. Please consult the factory for part numbers and availability.

5. WARRANTY & DISCLAIMER

ControlAir LLC products are warranted to be free from defects in materials and workmanship for a period of eighteen months from the date of sale, provided said products are used according to ControlAir LLC recommended usages. ControlAir LLC's liability is limited to the repair, purchase price refund, or replacement in kind, at ControlAir LLC's sole option, of any products proved defective. ControlAir LLC reserves the right to discontinue manufacture of any products or change products materials, designs or specifications without notice.

WARNING *These products are intended for use in industrial compressed-air systems only. Do not use these products where pressures and temperatures can exceed those listed under Specifications.*

Before using these products with fluids other than air, for non-industrial application, life-support systems, or other applications not within published specifications, consult ControlAir LLC



8 Columbia Drive
Amherst, NH 03031 USA
603-886-9400
Fax: 603-889-1844
www.controlair.com
sales@controlair.com