



Type 330/335/340/345 Series

Instrument Air Filter Regulator & Regulator

Type-330 Filter Regulator | Type-335 NACE Filter Regulator
Type-340 Regulator | Type 345 Filter

The Type 330/335/340/345 Series of Instrument Air Filter Regulators and Regulators are designed to provide clean, accurate air pressure to instruments, valves, and other automatic control equipment in a lightweight, compact housing. These quality instruments are constructed of durable materials that will provide long lasting performance in industrial environments.

Type 330 Filter Regulator

Designed for use in systems that require clean, accurate instrument air, the Type 330 provides pressure regulation and filtration in an integral compact package. Available in 1/4" NPT porting for normal operation and 1/2" NPT porting for high flow capacity requirements.

Type 330 Filter Regulator with Automatic Drain

Condensate waste liquid is automatically expelled from the bowl when the liquid reaches a specific level. The low maintenance Automatic Drain helps prolong the life of the regulator and filter by preventing corrosion on the bottom of regulator and reducing the load of the filter.

Type 335 NACE Filter Regulator

Materials in the Type 335 meet NACE MR-0175 requirements (available in 1/4" only)

Type 340 Regulator

Designed to provide accurate, constant control under variable flow rates and supply pressures. Compact and lightweight housing allows this unit to be mounted in applications where space is limited. Its durable construction withstands long term installation in harsh environments.

Type 345 Filter

The Type 345 Filter unit is a 40-micron depth filter that removes dirt, moisture and other particles from air and gas lines. Robustly constructed of die-cast aluminum with a baked epoxy finish, this unit stands up in corrosive operating conditions. This filter is an economical alternative for air supply line applications that don't require a pressure reducing regulator. Available in 1/4" and 1/2" NPT porting, manual and automatic drain. Optional 5 micron filter.

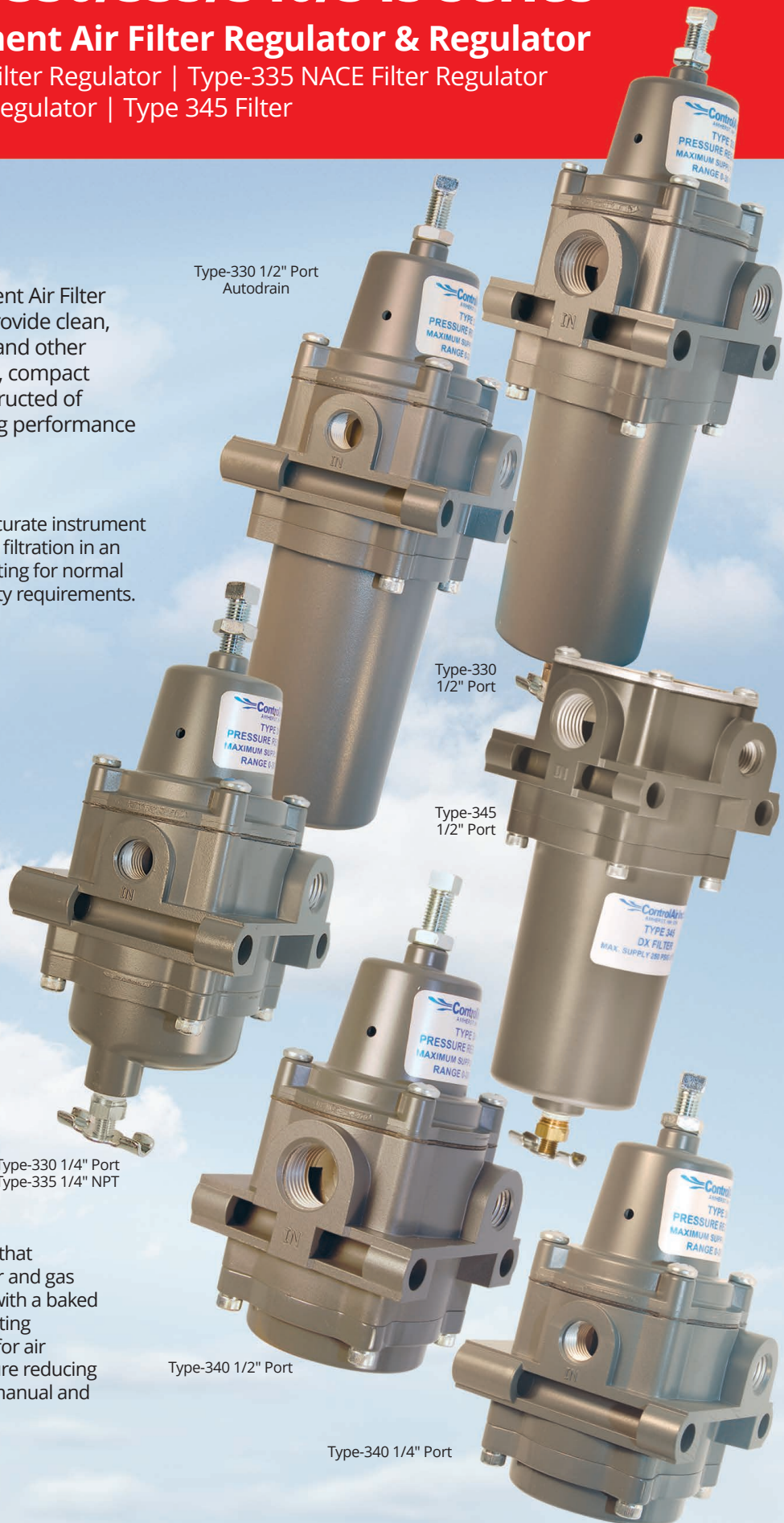

Type 330/335/340/345 Series Rugged and reliable instrument a



Specifications

In/Out Port Size (Gauge Ports 1/4 NPT)	1/4" NPT	1/2" NPT	1/4" NPT	1/4" NPT	1/2" NPT	1/4" NPT	1/2" NPT
Output Ranges	0-30 psig (0-2 bar) 0-60 psig (0-4 bar) 0-120 psig (0-8 bar)		0-30 psig (0-2 bar) 0-60 psig (0-4 bar) 0-100 psig (0-7 bar)		0-30 psig (0-2 bar) 0-60 psig (0-4 bar) 0-120 psig (0-8 bar)		N/A
Maximum Supply Pressure	Manual drain: 250 psig (17 bar) Auto drain: 150 psig (10 bar)		250 psig (17 bar)		250 psig (17 bar)		Manual drain: 250 psig (17 bar) Auto drain: 150 psig (10 bar)
Mounting	Pipe, bracket or through body direct						
Filter	40 micron (5 micron optional)			None		40 micron (5 micron optional)	
Cv Values	0.5 at 150 psig supply and 80 psig setpoint	2.5 at 150 psig supply and 80 psig setpoint	0.5 at 150 psig supply and 80 psig setpoint	0.5 at 150 psig supply and 80 psig setpoint	2.5 at 150 psig supply and 80 psig setpoint	0.5 at 150 psig supply and 80 psig setpoint	2.5 at 150 psig supply and 80 psig setpoint
Exhaust Capacity	0.1 scfm (2.83 NI/min) with downstream pressure 5 psig (0.3 bar) above set point					N/A	
Sensitivity	1" of water					N/A	
Air Consumption	Less than 5 scfh (2.5 NI/min)					N/A	
Effect of Supply Pressure Variation	Less than 0.25 psig (0.017 bar) for 25 psig (1.7 bar) change	Less than 0.5 psig (0.035 bar) for 25 psig (1.7 bar) change	Less than 0.25 psig (0.017 bar) for 25 psig (1.7 bar) change	Less than 0.25 psig (0.017 bar) for 25 psig (1.7 bar) change	Less than 0.5 psig (0.035 bar) for 25 psig (1.7 bar) change	N/A	
Temperature Limits	Manual drain: 0° to 160° F (-18° to 71° C) Auto drain: 32° to 160° F (0° to 71° C) Low Temp. Option: -62° to 194° F (-52° to 90° C)		-20° to 180° F (-29° to 82° C)		0° to 160° F (-18° to 71° C)		0° to 160° F (-18° to 71° C) 32° to 160° F (0° to 71° C) -62° to 194° F (-52° to 90° C)
Weight	Manual drain: 1.2 lbs (0.54 kg) Auto drain: 1.42 lbs (0.64 kg)	1.71 lbs (0.78 kg) 1.65 lbs (0.75 kg)	1.2 lbs (0.54 kg) N/A	1.15 lbs (0.52 kg) N/A	1.38 lbs (0.68 kg) N/A	1.0 lb (0.45 kg) 1.2 lb (0.54 kg)	1.5 lb (0.68 kg) 1.5 lb (0.68 kg)
Operating Media	Air, Inert Gas & Sweet Natural Gas		Air, Inert Gas & Sweet or Sour Natural Gas		Air, Inert Gas & Sweet Natural Gas		Air, Inert Gas & Sweet Natural Gas

Materials

Body	Diecast Aluminum Alloy, Chromate and Baked Epoxy Finish						
Filter	Polyethylene		Polyethylene		None		Polyethylene
Diaphragm, Gasket, Pintle	Nitrile Elastomer and Nylon Fabric Low Temp. Option: Silicone and Nitrile		Viton		Nitrile Elastomer and Nylon Fabric		Nitrile Elastomer and Nylon Fabric
Additional Materials	Brass, Zinc Plated Steel, Acetal		316 Stainless Steel, Aluminum, Heat Treated Plated Steel		Brass, Zinc Plated Steel, Acetal		

FLOW CURVES: Type 330/340: 1/4" NPT Units

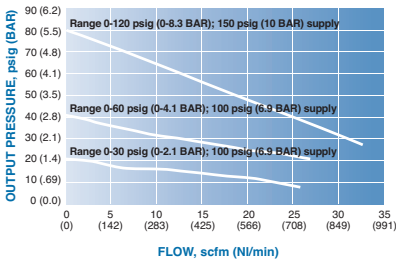

FLOW CURVES: Type 330/340: 1/2" NPT Units

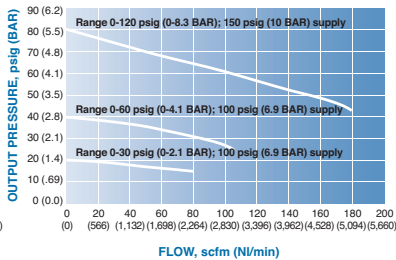

FLOW CURVES: Type 345: 1/4" NPT Units

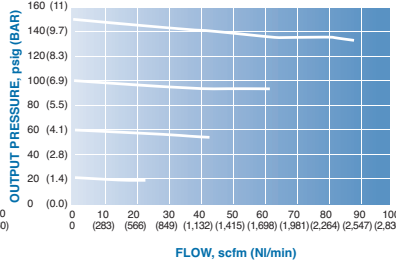

FLOW CURVES: Type 345: 1/2" NPT Units

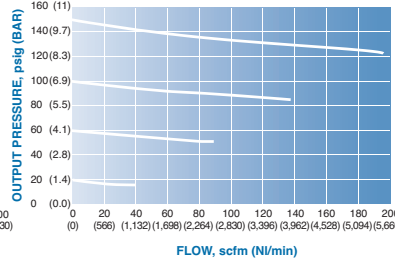

Type 330/345 Dimensions (1/4" and 1/2" NPT)

IN(mm)

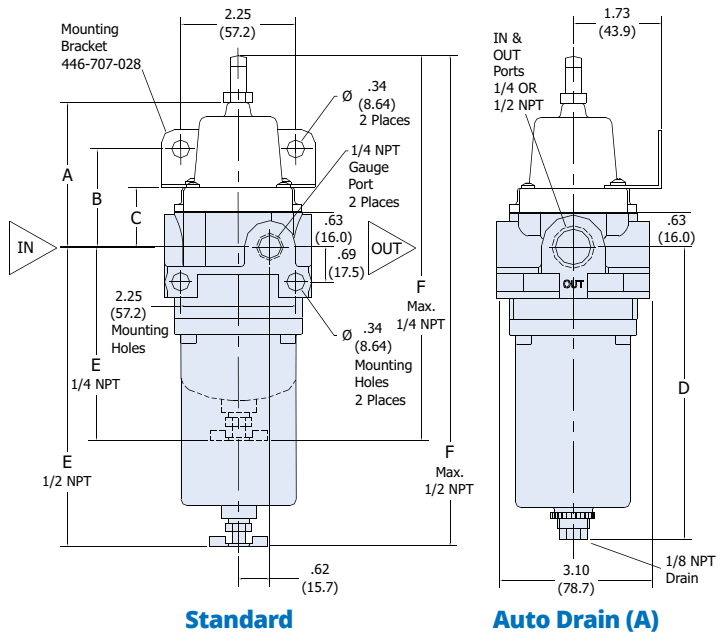

=Type 345

Type 340 Dimensions (1/4" and 1/2" NPT)

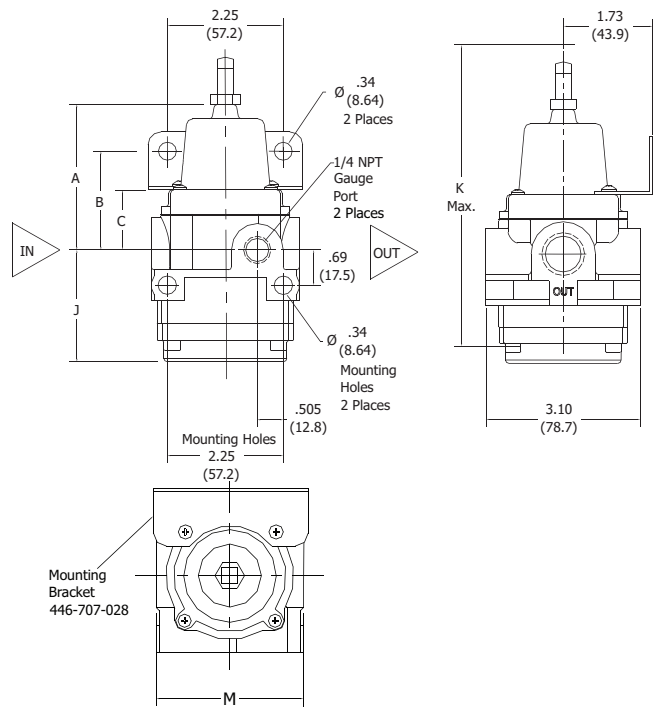

Sectional Drawings

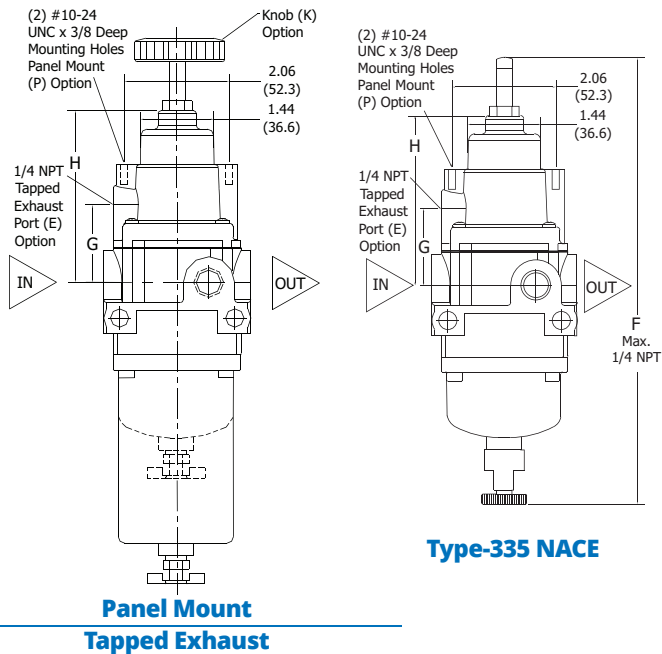
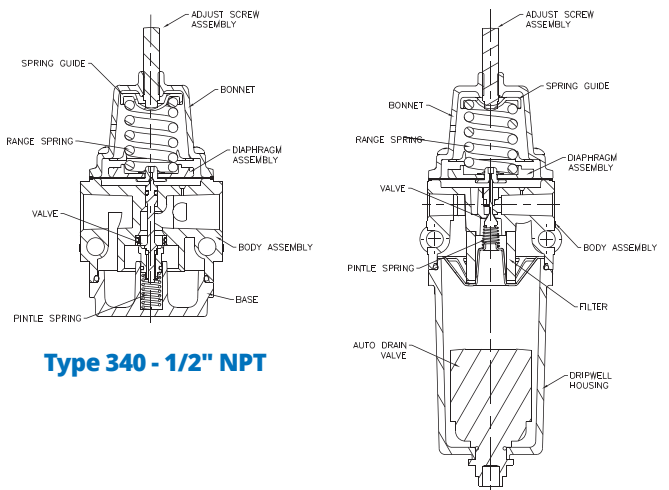

Port Size (NPT)	A		B		C		D		E		F		G		H		J		K		M	
	Inch	mm	Inch	mm	Inch	mm	Inch	mm	Inch	mm	Inch	mm	Inch	mm	Inch	mm	Inch	mm	Inch	mm	Inch	mm
1/4"	2.66	67.6	1.76	44.7	1.00	25.4	5.74	145.8	3.42	86.8	7.15	181.6	1.22	31.0	3.19	81.0	2.05	52.0	5.60	137.2	2.56	65.0
1/2"	2.83	71.9	1.93	49.0	1.17	29.7	5.84	148.3	6.05	153.7	9.78	248.4	1.39	35.3	3.36	85.3	2.15	54.6	5.77	146.6	2.88	73.2

Type 330/335/340/345 Series

Ordering Use this coding system to order

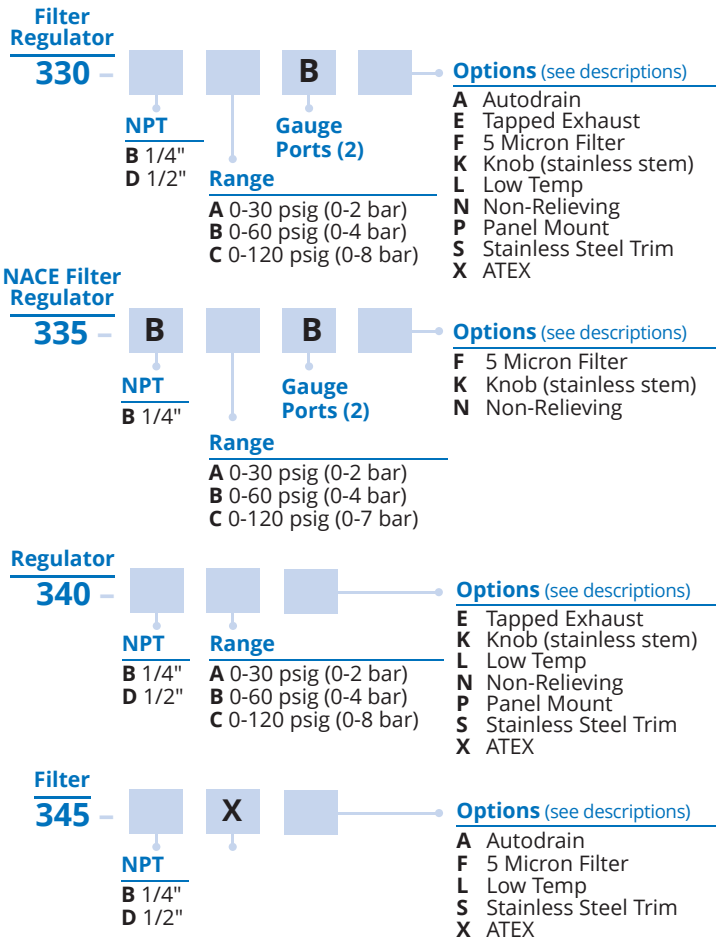

Options Add proper letter at end of model number.

- A** - Automatic Drain (Type 330 & 345): Float operated drain with 1/8" NPT connection. Maximum 150 psig supply pressure
 - E** - Tapped Exhaust: Allows captured exhaust. 1/4" NPT
 - F** - 5 Micron Filter: Standard 40 micron filter is replaced with 5 micron filter for more complete air filtration
 - K** - Knob: Hand wheel to replace square head adjust screw
 - L** - Low Temperature: Range -62°F to 194°F (-52°C to 90°C)
 - N** - Nonrelieving: For constant flow or downstream pressure relief applications
 - S** - Stainless Steel Trim: All external hardware (adjust stem/knob, drain valve, fasteners)
 - X** - ATEX 2014/34/EU
- Note: Options A and L cannot be combined.

Accessories

Mounting Bracket: P/N 446-707-028

Gauges: 1/4" NPT back-mount, 2" face, Dual Scale

Type 330, 340, 345

0-15 psi (0-1 bar) P/N 446-725-003

0-30 psi (0-2 bar) P/N 446-725-004

0-60 psi (0-4 bar) P/N 446-725-001

0-160 psi (0-10 bar) P/N 446-725-002

Type 335

0-30 psi (0-2.1) P/N 445-725-019

0-60 psi (0-4.1) P/N 445-725-020

0-160 psi (0-11) P/N 445-725-028



Principles of Operation - Type 330/335/340

Turning the adjusting screw changes the force exerted by the range spring on the diaphragm assembly. In equilibrium of set pressure, the force exerted by the range spring is balanced by the force from the output pressure acting underneath the diaphragm assembly. An unbalanced state between the output pressure and the set pressure causes a corresponding reaction in the diaphragm and supply valve assemblies. If the output pressure rises above the set pressure, an upward force is exerted on the diaphragm assembly causing the relief seat to lift and open. Excess pressure is vented to atmosphere until equilibrium is reached. If the output pressure drops below the set pressure the unbalanced force of the range spring causes a downward force on the diaphragm assembly. The supply valve then opens until the pressure builds up once more to the equilibrium condition. Under forward flow conditions, the range spring force is balanced by the diaphragm pressure force, with the supply valve open just enough to maintain the required equilibrium pressure. When high flow occurs, a specially designed aspirator helps maintain downstream pressure and compensates for droop.

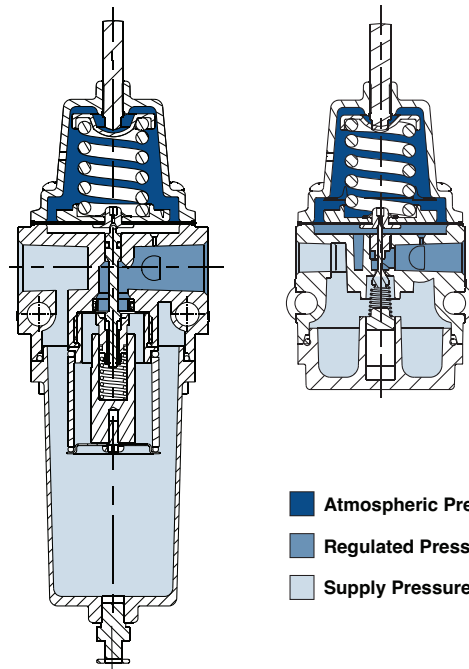

Warranty ControlAir LLC products are warranted to be free from defects in materials and workmanship for a period of eighteen months from the date of sale, provided said products are used according to ControlAir LLC recommended usages. ControlAir LLC's liability is limited to the repair, purchase price refund, or replacement in kind, at ControlAir LLC's sole option, of any products proved defective. ControlAir LLC reserves the right to discontinue manufacture of any products or change products materials, designs or specifications without notice. Note: ControlAir does not assume responsibility for the selection, use, or maintenance of any product. Responsibility for the proper selection, use, and maintenance of any ControlAir product remains solely with the purchaser and end user. Drawing downloads available at www.controlair.com



8 Columbia Drive / Amherst, NH 03031 USA / www.controlair.com / sales@controlair.com / 603-886-9400 / FAX 603-889-1844

An ISO 9001:2015 Registered Company

P/N 441-625-057 4/14/26