

TYPE 250 Lock-up Air Relay

INTRODUCTION

The Type-250 Lock-up Air Relay is designed so that when the supply air pressure falls below a set value (cut-off point) the unit traps the air pressure in the diaphragm chamber of the actuator. The cut-off set point is set to a desired value by compressing the spring adjusting screw. The cut-off set point is adjustable and is generally set at a higher value than required for operation of the control valve. If the control pressure is 3-15 psig (0.2 – 1.0 BAR), the cut-off set point could be set at 20 psig (1.35 BAR), for example.

In the typical installation example shown below, supply pressure is applied at Port **A**. As long as supply pressure stays above cut-off point, output pressure from the valve positioner is allowed to pass through Port **B** out to Port **C** which is output to the valve actuator. If supply pressure at Port **A** drops below the cut-off set point, Port **C** closes locking in place the output pressure to the actuator. If the supply pressure at Port **A** goes above the cut-off point the passage from Port **A** to Port **C** is again opened.

Typical Installation Illustration

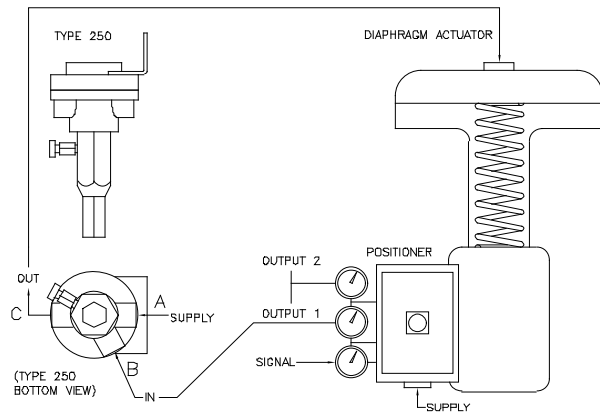

SPECIFICATIONS

Port Size (Inlet, Outlet, Supply)	1/4" NPT
Cut-off Pressure Range	30-120 psig (2-8 BAR) – Factory set point 113 psig (7.8 BAR)
Supply Pressure	125 psig (8.35 BAR) maximum
Temperature Limits	0° to -160°F (-18° to 71°C)
Weight	Aluminum: 2.1 lbs (0.95 kg) Stainless Steel: 4 lbs (1.8 kg)
Materials:	
Housing:	Aluminum or 304 Stainless Steel
Diaphragm:	Nitrile / Nylon
Spring:	Plated Steel
Plug:	Stainless Steel / Nitrile
Trim:	Stainless Steel
Bracket:	Plated Steel or 304 Stainless Steel

INSTALLATION

WARNING: Do not install lock-up relay where service conditions can exceed specifications.

Install the valve to achieve the desired lock-up results. Connect supply pressure to Port **A**, control pressure to Port **B** and output pressure to Port **C**.

Cut-Off Setting Adjustment

Cut-off set point value has been factory adjusted. Should it be required to re-adjust the set point, it can be made either while the unit is connected to the system or separately on the test bench. Inlet supply air and the outlet pressure gauge should be available to re-adjust.

To adjust the cut-off set point, remove the cap and adjust the spring adjusting screw until desired outlet cut-off pressure is achieved. Turning the adjusting screw clock-wise will increase the cut-off setting and turning it counter-clock wise will reduce the cut-off setting. Note that the lock-up relay has a differential pressure of 2.5 psig (0.17 BAR). Replace cap securely after having re-adjusted the cut-off set point.

Caution: Open the Manual Relief Valve to vent the actuator diaphragm chamber when control valve handwheel (override) is operated to avoid possible damage to the actuator diaphragm.

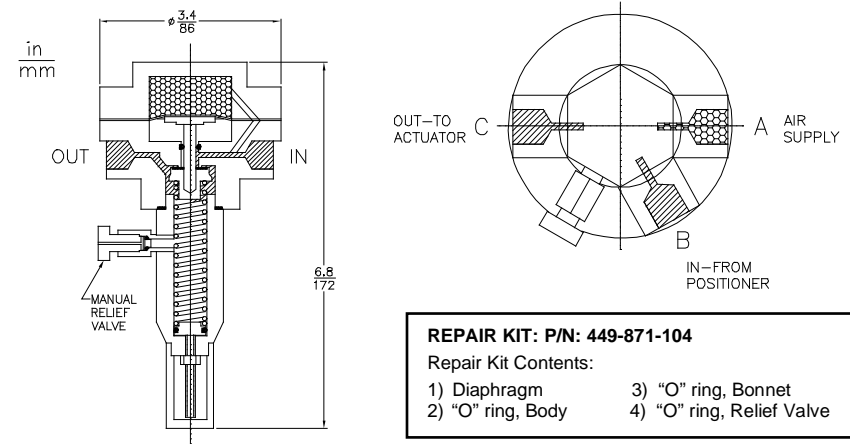

REPAIR KIT: P/N: 449-871-104

Repair Kit Contents:

1) Diaphragm	3) "O" ring, Bonnet
2) "O" ring, Body	4) "O" ring, Relief Valve

LIMITED WARRANTY & DISCLAIMER

ControlAir LLC products are warranted to be free from defects in materials and workmanship for a period of one year from the date of manufacture, provided said products are used according to ControlAir LLC recommended usages. ControlAir LLC's liability is limited to repair of, refund of purchase price paid for, or replacement in kind of, at ControlAir LLC's sole option, any products proved defective. ControlAir LLC reserves the right to discontinue manufacture of any product or change product materials, design or specifications without notice. Note: ControlAir does not assume responsibility for the selection, use, or maintenance of any product. Responsibility for the proper selection, use, and maintenance of any ControlAir product remains solely with the purchaser and end user.

WARNING: These products are intended for use in industrial compressed air systems only. Do not use these products where pressures and temperatures can exceed those listed under Specifications. Before using these products with fluids other than air, for non-industrial applications, life-support systems, or other applications not within published specifications, consult ControlAir LLC