

INSTALLATION

The ControlAir Precision Air Relay is designed for air service only. The Maximum supply pressure is 150 PSI. A filter (5 micron is recommended) should be installed ahead of the relay to prevent foreign matter in the air line from affecting the performance of the relay. Clean all air lines thoroughly to remove dirt and scale. Apply a small amount of compound to the male threads only and install the relay so that flow is in accordance with the IN and OUT ports. Make sure all connections are right and that the exhaust vents in the side of the relay are not blocked shut. The relay can be mounted in any position without affecting its operation. A pressure gauge may be attached to the relay by removing the gauge port plug.

MAINTENANCE

Occasional attention may be required due to the accumulation of foreign matter in the instrument. If gauge readings appear to fluctuate without cause, this usually indicates that the bleed screw requires cleaning. This can be done by merely removing it from the body and cleaning both the screen and the bleed screw. Make sure that no foreign matter is plugging the small orifice in the tip of the screw. If further attention is required repair kits and replacement parts may be purchased.

LIMITED WARRANTY & DISCLAIMER

ControlAir products are warranted to be free from defects in materials and workmanship for a period of eighteen months from the date of sale, provided said products are used according to ControlAir recommended usages. ControlAir's liability is limited to repair, purchase price refund, or replacement in kind, at ControlAir's sole option, of any products proved defective. ControlAir reserves the right to discontinue manufacture of any product or change product materials, design or specifications without notice. Note: ControlAir does not assume responsibility for the selection, use, or maintenance of any product. Responsibility for the proper selection, use, and maintenance of any ControlAir product remains solely with the purchaser and end user.

(2) Pipe Plug

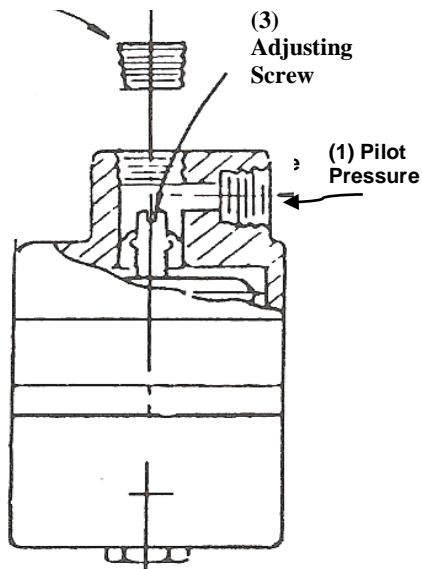

PROCEDURE FOR ADJUSTMENT OF BIAS:

1. Shut off, or disconnect the pilot-pressure air line.
2. Remove the pipe plug at the top of the relay.
3. Adjust the servo-control capsule by rotating the adjusting screw with a screwdriver.

When viewed from the top:

- a. Turning the screw clockwise will increase the output pressure relative to any given signal pressure.
- b. Turning the screw counter-clockwise will decrease the output pressure relative to any given signal pressure.

The output pressure will change about 7 psi for each quarter turn of the screw.

4. Replace the plug in the top of the relay, making sure it is seated firmly so that it does not leak.
5. Allow the signal pressure to actuate the relay, and verify the output pressure to check your adjustments.
6. The above procedure can be used to "zero" the relay for a direct 1:1 output relative to the signal pressure, or it may be used to provide positive or negative bias to the relay.

WARNING: These products are intended for use in industrial compressed air systems only. Do not use these products where pressures and temperatures can exceed those listed under Specifications. Before using these products with fluids other than air, for non-industrial applications, life-support systems, or other applications not within published specifications, consult ControlAir LLC.