



Type 1230

High Flow Gas Pressure Regulator

Reliable pressure control for the oil and gas industry

The Type 1230 is a pressure-reducing, direct-operated regulator suitable for use with compressed air, natural gas, or an assortment of other inert gases.

The Type 1230 utilizes a similar design to the Type 1227 but provides a much broader offering of output pressure ranges and valve disk materials.

The Type 1230 is available with output pressures that span from 50 psi to 500 psi making it suitable for use across a vast range of industries and applications, especially those utilizing regulators in series for controlled pressure reduction across multiple stages.

Features

- 1" or 2" body size
- Trim can be replaced without disconnecting regulator from the system
- Can be re-arranged into multiple orientations for difficult installations with limited maneuverability
- NACE MR-0175 configurations available
- Assembled and Tested in the USA

Materials of Construction

	Standard (S)	Nace (N)
Body, Bonnet, Diaphragm Case	LCC Steel	LCC Steel
Diaphragm	Neoprene	Fluorocarbon
Valve Disk	Nitrile or Nylon	Fluorocarbon or Nylon
Trim	Brass and Aluminum (stainless option)	Stainless Steel

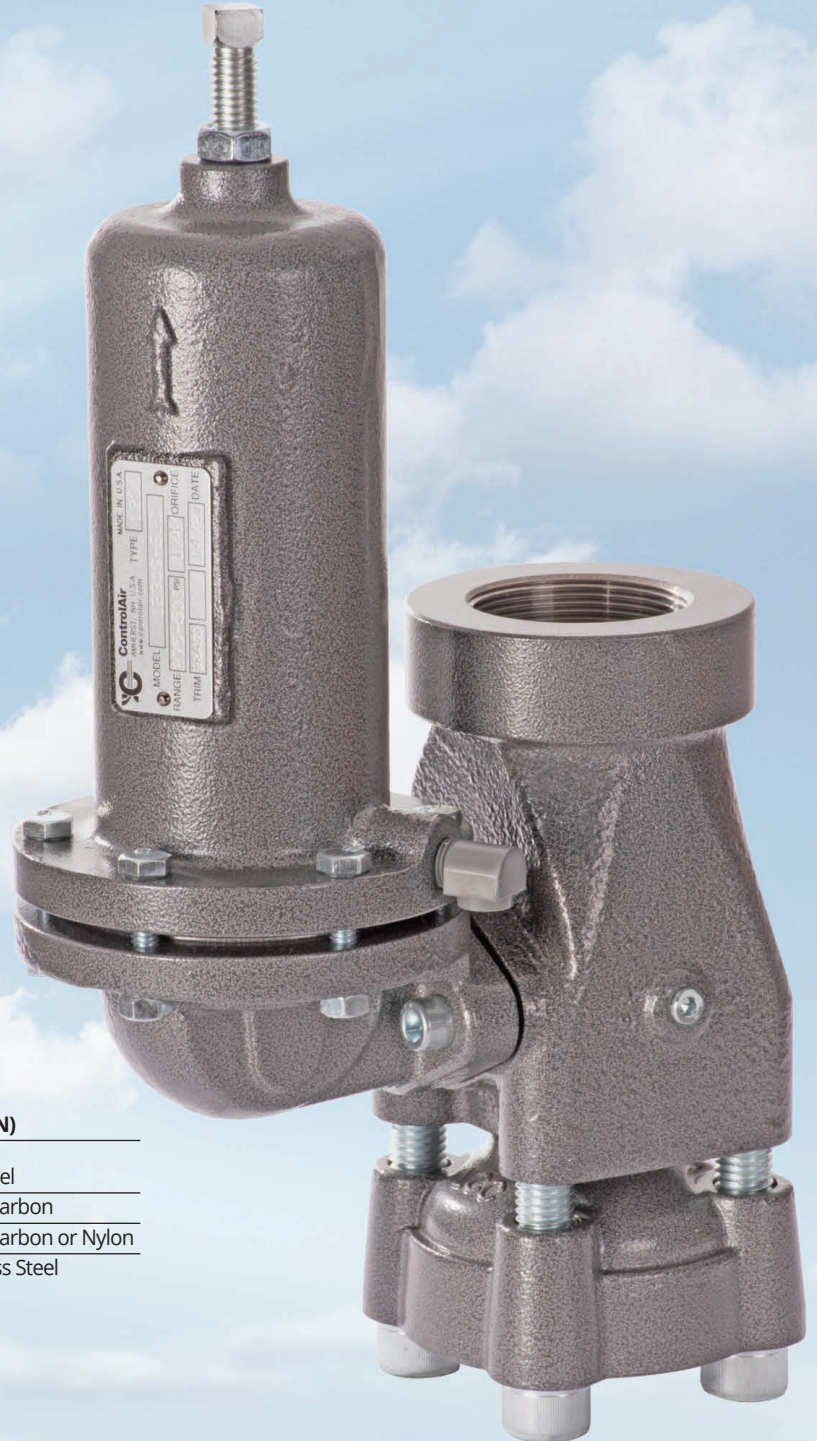

Type 1230 High Flow Gas Pressure Regulator

Table 1 Maximum Inlet Pressure by Orifice Size

Orifice Size		Maximum Inlet Pressure	
in.	mm	psi	bar
1/8	3.2	1500	103
3/16	4.8	1500	103
1/4	6.4	1500	103
3/8	9.5	1000	69
1/2	13	750	51.7

Table 2 Maximum Pressure Drop by Orifice Size and Disk Material

Orifice Size		Maximum Pressure Drop*							
		Nitrile (NBR) Disk		Fluorocarbon (FKM) Disk		CTFE Disk		Nylon (PA) Disk	
in.	mm	psi	bar	psi	bar	psi	bar	psi	bar
1/8	3.2	600	41.4	200	13.8	1500	103	1500	103
3/16	4.8	600	41.4	200	13.8	1500	103	1500	103
1/4	6.4	600	41.1	200	13.8	1000	69	1000	69
3/8	9.5	500	34.5	200	13.8	500	34.5	500	34.5
1/2	13	250	17.2	200	13.8	250	17.2	250	17.2

* The inlet pressure cannot exceed the sum of the output pressure setting and the maximum pressure drop.

Note: Nitrile valve disks are furnished for pressure ranges up to 150 psig (10 bar) for better wear resistance. Nylon valve disks are furnished for higher pressure ranges over 150 psig (10 bar).

Example: For a regulator with 1/2" orifice size, NBR disk material, and set point of 100 psi, the maximum inlet pressure would be 350 psi = 250 psi (maximum pressure drop for 1/2" & NBR) + 100 psi (set point)

Table 3 Flow Coefficient for Relief Valve Sizing

Orifice Size		C _g	C _v	C ₁
in.	mm			
1/8	3.2	13.9	0.49	26.4
3/16	4.8	31.3	1.11	28.2
1/4	6.4	55.1	2.03	27.2
3/8	9.5	122.5	4.61	26.6
1/2	13	216.0	8.18	26.4

Table 4 Flow Capacities in SCFH at 20% droop of Natural Gas (0.6 Specific Gravity)

Output Range	Set Point (psi)	Inlet Pressure (psi)	Orifice Size (in.)									
			1" NPT Body Size					2" NPT Body Size				
			1/8	3/16	1/4	3/8	1/2	1/8	3/16	1/4	3/8	1/2
27-50 psi (1.9-3.5 bar)	50	60	900	2000	3100	5200	8100	1000	2100	3200	5300	12000
		100	1700	3500	5700	10500	13000	1800	3600	5800	10000	21000
		200	3500	7800	11000	16000	19000	3600	7900	12000	21000	55000
		300	5300	10500	14000	20000	23000	5500	11000	19000	48000	83000
		400	6900	13000	17000	23000		7000	15000	27000	63000	
		500	8700	15000	19000	25000		8800	19000	34300	79700	
		600	9800	17000	21000			10000	23000	42000		
		1000	16200	22300	26300			18000	39900	70400		
46-95 psi (3.2-6.6 bar)	50	60	800	1500	2400	4300	6400	900	1600	2500	4400	7300
		100	1500	3100	4200	7500	10000	1600	3400	4300	7600	12000
		200	3400	6800	9400	14000	17000	3500	6700	9600	16000	27000
		300	5200	8900	11000	16000	20000	5300	10000	14000	27000	51000
		400	6800	11000	15000	20000		6900	13000	21000	46000	
		500	8600	12300	16300	22000		8700	16300	26300	73300	
		600	9800	14000	19000			10000	20000	35000		
		1000	13500	18400	21700			17100	38700	68800		
	75	100	1700	3200	5000	8000	13000	1800	3300	5200	9000	14000
		200	3500	7300	10000	16000	22000	3600	7400	11000	19000	30000
		400	7100	14000	19000	27000		7200	15000	24000		
		500	8600	16300	21300	28700		8700	19000	31400		
		600	9900	19000	25000			10000	23000	39000		
		1000	16700	25800	31000			17600	39000	69300		
1500	23000	32000				24000	60000					

(continued)

Table 4 Flow Capacities in SCFH at 20% droop of Natural Gas (0.6 Specific Gravity) (continued)

Output Range	Set Point (psi)	Inlet Pressure (psi)	Orifice Size (in.)									
			1" NPT Body Size					2" NPT Body Size				
			1/8	3/16	1/4	3/8	1/2	1/8	3/16	1/4	3/8	1/2
90-150 psi (6.2-10.3 bar)	100	125	2000	3600	5500	9200	13000	2100	3700	5600	9800	15000
		200	3600	6600	9400	13000	22000	3700	6900	10000	17000	27000
		400	7000	13000	18000	27000		7200	14000	21000	39000	
		500	8300	15500	20500	31000		8600	17500	27500	54000	
		1000	17500	26000	32600			17200	38600	66000		
	1500	25000	35000				27000	59000				
	125	150	2400	4600	6700	11000	17000	2500	5000	8100	12000	20000
		300	5200	10000	15000	25000	34000	5300	11000	17000	31000	48000
		500	7900	15000	25000	36000		8800	19000	30000	59000	
		1500	26000	43000				27000	60000			
	150	200	3400	6800	10000	16000	26000	3500	7300	11000	18000	30000
		400	7100	14000	22000	34000	42000	7200	15000	26000	46000	77000
		800	13000	29000	38000			14000	30000	54000		
		1500	26000	47000				27000	60000			
	150-200 psi (10.3-13.8 bar)	150	200	3400	6200	9300	16000	26000	3500	6900	10000	17000
400			7100	14000	21000	32000	38000	7200	15000	24000	40000	66000
800			13000	27000	37000			14000	30000	51000		
1500			26000	44000				27000	60000			
200		250	4200	8300	12000	20000	30000	4300	9100	13000	23000	42000
		600	9500	22000	34000	55000		10000	23000	40000	75000	
		800	13000	30000	43000			14000	31000	54000		
		1200	20000	41000	59000			21000	48000	83000		
		1500	26000	53000				27000	60000			
		2000	34000	66000				35000	78000			
200-275 psi (13.8-19 bar)	200	250	4200	8200	11000	20000	29000	4300	8900	12000	23000	35000
		600	9500	22000	31000	51000		10000	23000	38000	70000	
		800	13000	29000	42000			14000	31000	52000		
		1200	19000	41000	55000			20000	46000	83000		
		1500	26000	51000				27000	60000			
	250	300	4900	9000	15000	28000	42000	5000	10000	17000	30000	52000
		500	8500	18000	29000	51000	65000	8600	19000	34000	62000	103000
		1000	16000	39000	58000			17000	40000	68000		
		1500	26000	59000				27000	60000			
	275	300	4700	9000	15000	28000	39000	4800	10000	17000	29000	43000
		600	9300	21000	39800	76100		10000	23000	40800	81900	
		1000	16000	39000	67000			17000	40000	68000		
1500		26000	60000				26000	61000				
275-500 psi (19-34.5 bar)	275	300	4500	7500	10000	20000	31000	4600	8400	13000	23000	37000
		600	9300	18400	24300	43800		10000	23000	40800	81900	
		1500	26000	46000				27000	57000			
	300	400	6600	11000	16000	31000	42000	7000	13000	21000	35000	54000
		700	11000	23000	30000	54000		12000	26000	40000	72000	
		1000	16800	32500	43800			15800	33200	53600		
		1500	26000	49000				27000	58000			
	400	500	8300	16000	24000	44000	62000	8800	17000	28000	49000	77000
		800	13000	30000	41000	76000		14000	31000	51000	95000	
		1000	17000	38000	54000			18000	40000	66000		
		1400	24000	55000	76000			25000	57000	96000		
		1500	26000	60000				27000	61000			
	500	550	8700	16000	26000	50000	77000	9000	18000	30000	53000	89000
		900	15000	34000	52000	92000		16000	35000	60000	113000	
		1500	26000	59000	72000			27000	60000	82000		

Note: To convert SCFH to Nm³/h, multiply the SCFH flow capacity by 0.02832

Type 1230 High Flow Gas Pressure Regulator

Dimensions inch [mm]

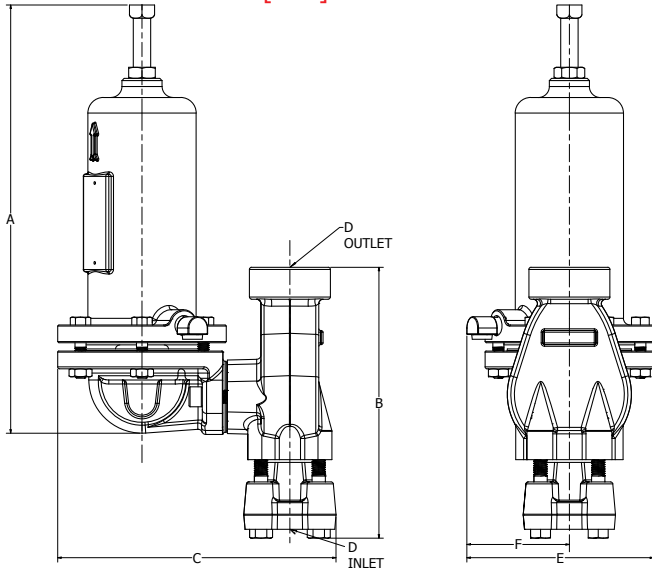

	A	B	C	D	E	F
1" Body	12.07 [306.5]	7.63 [193.9]	7.84 [199.2]	1" NPT	5.26 [133.7]	2.89 [73.4]
2" Body	12.07 [306.5]	8.58 [218.0]	8.48 [215.4]	2" NPT	5.26 [133.7]	2.89 [73.4]

Specifications

Body Sizes	1" or 2" NPT
Vent Size	1/4" NPT
Output Ranges Note: Nitrile seat disks standard for ranges below 150 psig (10 bar)	27-50 psi (1.9-3.5 bar), 46-95 psi (3.2-6.6 bar), 90-150 psi (6.2-10.3 bar)
Note: Nylon seat disks standard for ranges over 150 psig (10 bar)	150-200 psi (10.3-13.8 bar), 200-275 psi (13.8-19 bar), 275-500 psi (19-34.5 bar)
Maximum Inlet Pressure	see Table 1
Body Inlet Pressure Rating	1,500 psi (103 bar)
Orifice Sizes	1/8", 3/16", 1/4", 3/8", 1/2"
Maximum Outlet Pressure	500 psi (39.7 bar)
Maximum Outlet Pressure Above Set Point	200 psi (13.8 bar)
Maximum Pressure Drop	see Table 2
Flow Coefficients	see Table 3
Flow Capacities	see Table 4
Temperature Limits	
Elastomer Material	
Neoprene (CR), Nitrile (NBR) & Nylon (PA)	-40°F to 180°F (-40°C to 82°C)
Fluorocarbon (FKM) and CTFE	0°F to 180°F (-18°C to 82°C)
Weights	
1" NPT / DN 25 Body	25 lbs. (11.3 kg)
2" NPT / DN 50 Body	30 lbs. (13.6 kg)
Operating Media	Compressed Air, Natural Gas, Other Inert Gases

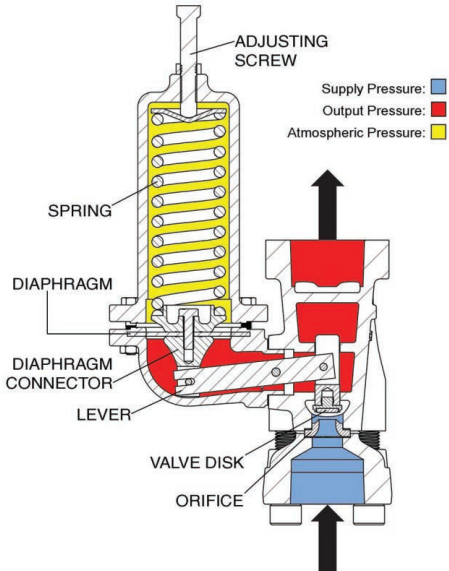

Principles of Operation

Note: The ControlAir Type 1230 High Flow Gas Pressure Regulator does not include internal relief. Therefore, if the inlet pressure is able to exceed the diaphragm casing pressure rating, the user must provide a pressure relieving device.

Ordering Use this coding system to order

Model 1230	Version S Standard N NACE	Port Size (NPT) F 1" G 2"	Orifice Size B 1/8" C 3/16" D 1/4" E 3/8" F 1/2"	Options S Stainless Trim (1230S only, standard on 1230N) N Nylon Valve Disk Note: Nylon seat disks standard for ranges over 150 psig (10 bar) (see specifications above) T CTFE Valve Disk B Nitrile Valve Disk (1230N only, standard on 1230S)
Spring Range D 27-50 psi (1.9-3.5 bar) E 46-95 psi (3.2-6.6 bar) F 90-150 psi (6.2-10.3 bar) G 150-200 psi (10.3-13.8 bar) H 200-275 psi (13.8-19 bar) I 275-500 psi (19-34.5 bar)				

Warranty ControlAir LLC products are warranted to be free from defects in materials and workmanship for a period of eighteen months from the date of sale, provided said products are used according to ControlAir, Inc. recommended usages. ControlAir LLC's liability is limited to the repair, purchase price refund, or replacement in kind, at ControlAir LLC's sole option, of any products proved defective. ControlAir LLC reserves the right to discontinue manufacture of any products or change products materials, designs or specifications without notice. For latest revision, see ControlAir.com. Note: ControlAir does not assume responsibility for the selection, use, or maintenance of any product. Responsibility for the proper selection, use, and maintenance of any ControlAir product remains solely with the purchaser and end user. Drawing downloads available at www.controlair.com



8 Columbia Drive / Amherst, NH 03031 USA / www.controlair.com / sales@controlair.com / 603-886-9400 / FAX 603-889-1844

An ISO 9001:2015 Registered Company