



Type 1005V

Electronic Vacuum Regulator

The Type 1005V Electronic Vacuum Regulator is a closed loop design, consisting of 2 solenoid valves, one pressure transducer and an electronic board that performs PID closed loop control. According to the input electronic signal, one valve opens up the vacuum inlet, and the other valve acts as vacuum breaker. Whilst increasing the vacuum level, the inlet valve acts upon the internal piston and allows air to be withdrawn. The internal pressure transducer senses the vacuum level and provides feedback to the electronic board which in turn controls the action of two valves until the target vacuum level is reached. ControlAir's Vacuum Pressure Regulator receives input signal of 0-10V, 4-20mA or RS485-modbus.

Features

- **Electronic closed-loop**
Minimizes effects of vibration, mounting position, temperature and supply pressure
- **Versatile control**
Digital or analog input and output configurations
- **IP65 compliant**
Suitable for wet or dirty environments
- **M12 cable**
2 meter cable supplied with each unit

Specifications

Vacuum Range	-14.5 to 0 psi (-1 to 0 bar / -100 to 0 kPa)
Input Signal	0-10V / 4-20mA / RS485 Modbus
Monitor Output	0-10V / 4-20mA / 1-5V
Power Supply	DC24V
Electrical Connection	M12 Connection
Response	0.8S
Ambient Temperature	32° to 158°F (0° to 70°C)
Weight	1.21 lbs (0.55 kg)
Port Size	1/4" NPT
Repeatability	±0.1% full scale
Hysteresis	±0.3% full scale
Linearity	±0.1% full scale
Accuracy	±0.5% full scale
Flow Rate	22 scfm (640L/min) @ full open
Media	Clean, dry, oil-free, instrument air, filtered to 5 micron



Type 1005V Electronic Vacuum Regulator

Dimensions

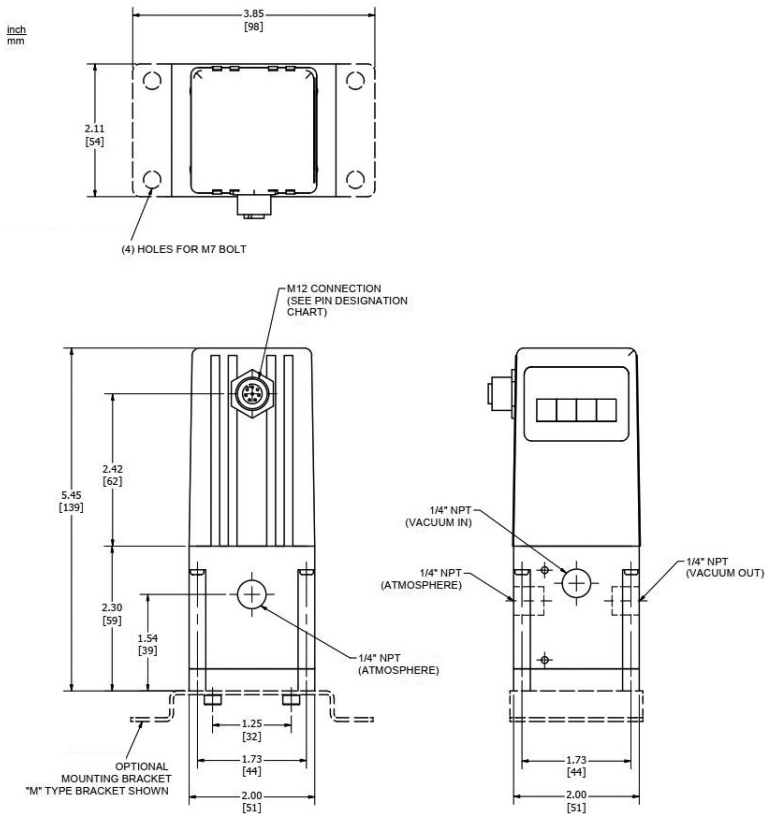

Ordering Use this coding system to order

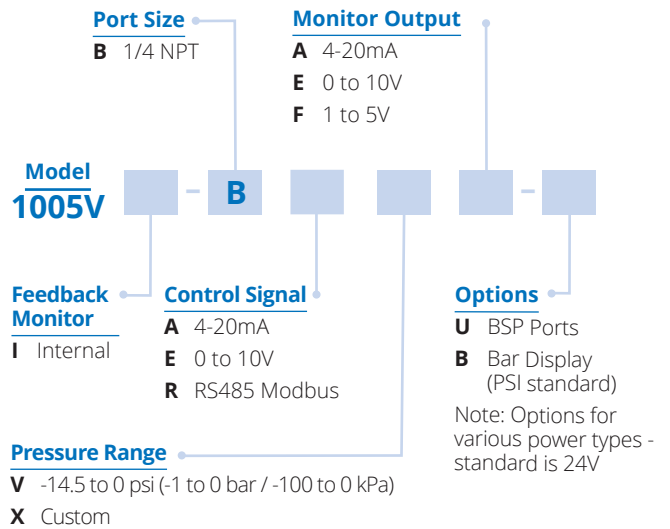

Accessories

Bracket Kits:

'L' type P/N: 449-542-055

'M' type P/N: 449-542-059

Warranty ControlAir LLC products are warranted to be free from defects in materials and workmanship for a period of eighteen months from the date of sale, provided said products are used according to ControlAir LLC recommended usages. ControlAir LLC's liability is limited to the repair, purchase price refund, or replacement in kind, at ControlAir LLC's sole option, of any products proved defective. ControlAir LLC reserves the right to discontinue manufacture of any products or change products materials, designs or specifications without notice. Note: ControlAir does not assume responsibility for the selection, use, or maintenance of any product. Responsibility for the proper selection, use, and maintenance of any ControlAir product remains solely with the purchaser and end user. Drawing downloads available at www.controlair.com



8 Columbia Drive / Amherst, NH 03031 USA / www.controlair.com / sales@controlair.com / 603-886-9400 / FAX 603-889-1844

An ISO 9001:2015 Registered Company

P/N 441-625-083 2/15/24