

Type 500X

Electropneumatic Transducer (I/P, E/P) Installation, Operation and Maintenance Instructions



Ordering Information

Type 500X I/P Transducers

Part Number	Input	Output Range		Impedance
		psi	bar	
500-AA	4-20 mA	3-9	0.2-0.6	90 Ohms
500-AB	4-20 mA	9-15	0.6-1.0	90 Ohms
500-AC	4-20 mA	3-15	0.2-1.0	180 Ohms
500-AD	4-20 mA	3-27	0.2-1.9	220 Ohms
500-AE	4-20 mA	6-30	0.4-2.0	220 Ohms
500-AF	4-20 mA	1-17	0.1-1.2	250 Ohms
500-BC	10-50 mA	3-15	0.2-1.0	70 Ohms
500-BD	10-50 mA	3-27	0.2-1.9	85 Ohms
500-BE	10-50 mA	6-30	0.4-2.0	85 Ohms
500-AG	4-20 mA	2-60*	0.1-4.0	225 Ohms
500-AH	4-20 mA	3-120*	0.2-8.0	260 Ohms
500-BF	0-60 mA	2-120*	0.1-8.0	220 Ohms

Type 500X E/P Transducers

Part Number	Input	Output Range		Impedance
		psi	bar	
500-CC	0-5 VDC	3-15	0.2-1.0	615 Ohms
500-CD	0-5 VDC	3-27	0.2-1.9	530 Ohms
500-CE	0-5 VDC	6-30	0.4-2.0	530 Ohms
500-DC	1-9 VDC	3-15	0.2-1.0	985 Ohms
500-DD	1-9 VDC	3-27	0.2-1.9	840 Ohms
500-DE	1-9 VDC	6-30	0.4-2.0	840 Ohms
500-CF	0-5 VDC	2-60*	0.1-4.0	500 Ohms
500-EH	0-10 VDC	3-120*	0.2-8.0	805 Ohms

*Output shown is as calibrated at the factory. Large span adjustment capability allows recalibration to achieve output ranges from 3-35 psig (0.2-2.4 bar) with 2-60 psig unit to 3-145 psig (2.0-10 bar) with 2-120 psig unit.

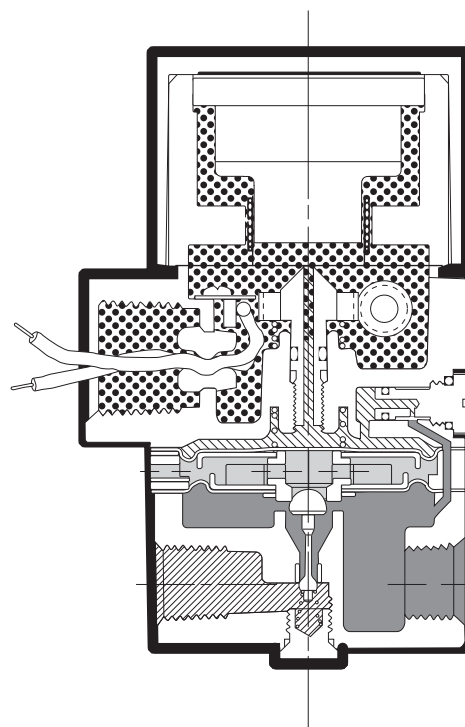

Pilot Pressure Supply Pressure
 Atmospheric Pressure Output Pressure

Contents

Section	Description	Page
1.0	Description & Installation	2
2.0	Operation	3
3.0	Maintenance	5
4.0	Troubleshooting	5
5.0	Warranty	5



8 Columbia Drive / Amherst, NH 03031 USA
 Website: www.controlair.com
 Email: sales@controlair.com
 603-886-9400 FAX 603-889-1844

An ISO-9001:2008 Certified Company

DANGER, WARNING, CAUTION and NOTE statements

DANGER	Refers to conditions or hazards which could result in serious personal injury or death.
WARNING	Refers to conditions or hazards which could result in personal injury.
CAUTION	Refers to conditions or hazards which could result in equipment or property damage.
NOTE	Alerts you to facts or special instructions.

ALL DANGER, WARNING, AND CAUTION NOTICES MUST BE COMPLIED WITH IN FULL

SPECIFICATIONS

	Low Output Range (Up To 30 Psig)	High Output Range (Up To 120 Psig)
Min./Max. Supply Pressure	Minimum - 3 psig (.21 BAR) above maximum output. Maximum - 100 psig (7 BAR)	Minimum - 5 psig (0.35 BAR) above maximum output Maximum - 150 psig (10.5 BAR)
Supply Pressure Sensitivity	<± 0.1% of span per psig (<± 0.15% of span per 0.1 BAR)	<± .04% of span per 1.0 psig (0.07 BAR)
Terminal Based Linearity	<± 0.75% of span	<± 1.5% of span typical, ± 2.0% max.
Repeatability	< 0.5% of span	< 0.5% of span
Hysteresis	< 1.0% of span	< 0.5% of span
Response Time	Dependent on pressure range - typically less than 0.25 sec for 3-15 psig units	
Flow Rate	4.5 scfm (127 NI/min) at 25 psig (1.7 BAR) supply 12.0 scfm (340 NI/min) at 100 psig (6.8 BAR) supply	20.0 scfm (566 NI/min) at 150 psig (10.5 BAR) supply
Maximum Air Consumption	.05 scfm (1.4 NI/min) midrange typical	.07 scfm (2 NI/min) midrange typical
Media	Oil free, clean dry air filtered to 40 micron	
Electrical Connections	Conduit 1/2" NPT (standard); DIN 43650 (optional)	
Enclosure	Nema 1 (standard); Nema 4X(IP65) (optional)	
Temp. Range (Operating)	-20°F to +140°F (-30°C to 60°C)	
Port Sizes	1/4 NPT (Pneumatic) 1/2 NPT (Electric)	1/4 NPT (Pneumatic) 1/2 NPT (Electric)
Relief Capacity	2 scfm (56.6 NI/min) at 5 psig (2.4 BAR) above 20 psig (1.3 BAR) setpoint	7 scfm (198 NI/min) at 10 psig (0.7 BAR) above 20 psig (1.3 BAR) setpoint
Weight	2.1 lbs. (0.94 kg)	2.1 lbs. (0.94 kg)

1. DESCRIPTION and INSTALLATION

1.1 Description

- 1.1.1 The ControlAir Type 500X converts a current or voltage input signal to a linearly proportional pneumatic output pressure. This versatile instrument is designed for control applications that require a high degree of reliability and repeatability at an economical cost.

1.2 Principle of Operation

- 1.2.1 The Type 500X is a force balance device in which a coil is suspended in the field of a magnet by a flexure. Current flowing through the coil generates axial movement of the coil and flexure. The flexure moves towards the nozzle and creates back pressure which acts as a pilot pressure to an integral booster relay. Input signal increases (or decreases for reverse acting) cause proportional output pressure increases.

Zero and Span are calibrated by turning adjust screws on the front face of the unit. Adjustment of the zero screw repositions the nozzle relative to the flexure. The span adjustment is a potentiometer that controls the amount of current through the coil.

1.3 Mounting

- 1.3.1 Unit may be pipe, panel, or bracket mounted. Mounting may be at any angle, though may require field adjustment. High external vibration may cause output fluctuations. Mounting in a vibration-free area is recommended.

1.4 Pneumatic Connections

- 1.4.1 The 1/4 NPT supply and output ports are marked "IN" and "OUT" respectively on the base of the unit. Clean all pipe lines to remove contamination before installation. Apply pipe compound to male threads of the air line only. Avoid getting compound in the air lines.

Clean dry instrument quality air must be used. To insure optimum performance supply pressure should be regulated. To provide stable inlet pressure and prevent contamination of the internal section of the transducer the use of an Instrument Air Filter Regulator is recommended.

The two unmarked ports on the base of the unit are gage ports but may be used as alternative output ports. Any unused ports must be plugged.

WARNING The I/P transducer enclosure contains aluminum and is considered to constitute a potential risk of ignition by impact or friction and must be taken into account during installation.

1.5 Electrical Connections

- 1.5.1 Electrical connections are made to the black and white leads extending out from the 1/2 NPT conduit fitting. When the positive side of the input signal is connected to the black lead, the output pressure will increase as the input signal increases.

Figure 1 DIN 43650 Connector

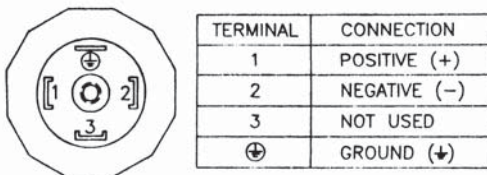

2. OPERATION

2.1 Calibration

- 2.1.1 Zero and Span should always be checked after mounting. If unit is calibrated in a vertical position and then mounted at an angle, readjustment of the zero is necessary. To calibrate use the following procedure:
1. Open protective covers to expose zero and span adjustment screws.
 2. Connect the recommended air supply to the inlet of the transducer and an accurate pressure gage to the outlet.
 3. Connect the electrical input and set the input signal to the minimum value of the range being used (e.g. 4 mA for a 4-20 mA unit).
 4. Observe the output pressure. If necessary adjust zero screw until reaching minimum output pressure setting. Turn zero screw counter clockwise to increase pressure, clockwise to decrease pressure.
 5. Increase electrical input signal to its maximum value (e.g. 20 mA for a 4-20 mA unit).
 6. Observe the output pressure. If necessary adjust the span screw until reaching maximum output pressure setting.

NOTE For I/P (current) input models turn span screw counter clockwise to increase pressure, clockwise to decrease pressure. For E/P (voltage) input models turn span screw clockwise to increase pressure, counter clockwise to decrease pressure.

7. The Zero and Span adjustments are interactive. After adjusting the span it will be necessary to recheck the zero. Repeat steps 3-6 until both end points are at the required values.

Figure 2 Electrical Schematic

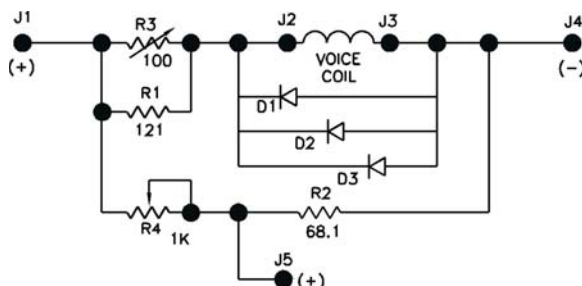

Notes:

1. For 4-20 mA and 10- mA use J1 as positive input.
2. For 10-50 mA change R4 to 100 Ohms.
3. For 1-9 VDC and 0-10 VDC remove R2, use J5 as positive input.

2.2 Dimensional Drawings (Dimensions are $\frac{\text{in.}}{\text{mm}}$)

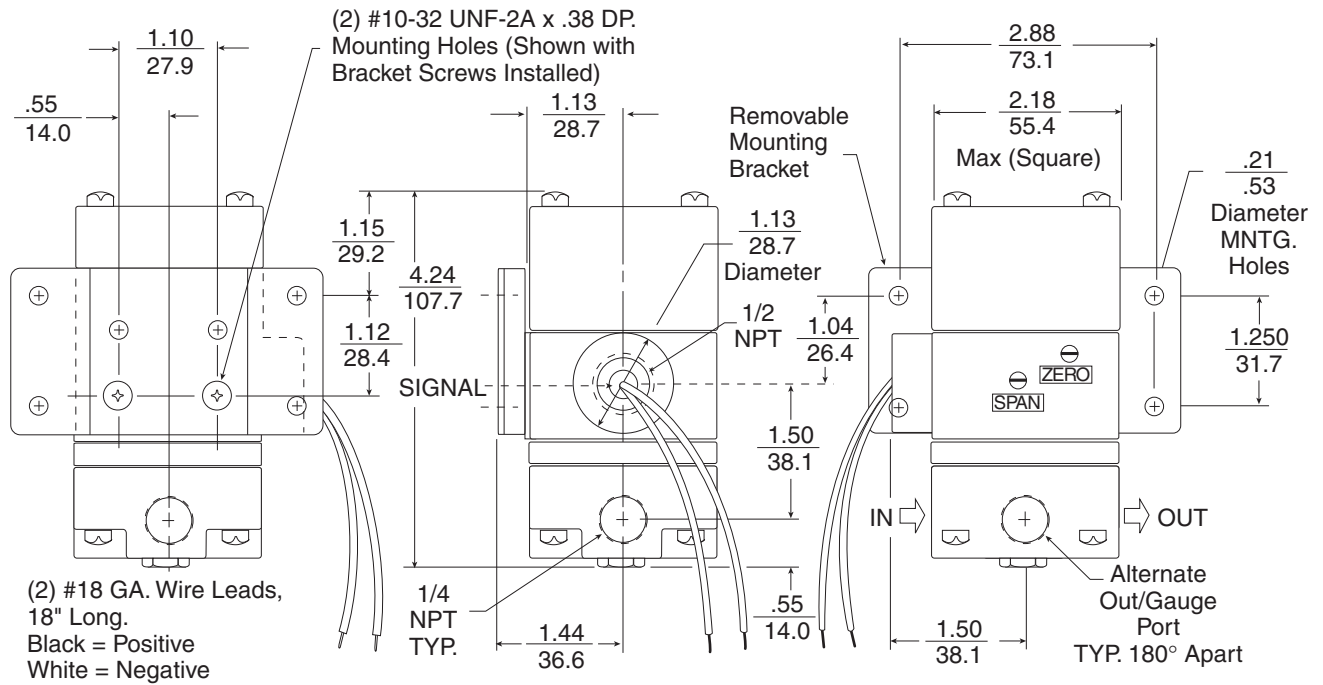

2.3 Intrinsically Safe Operation

2.3.1 ControlAir, Inc. offers Factory Mutual Intrinsically Safe approval as a standard feature on all units with a 4-20 mA input signal.

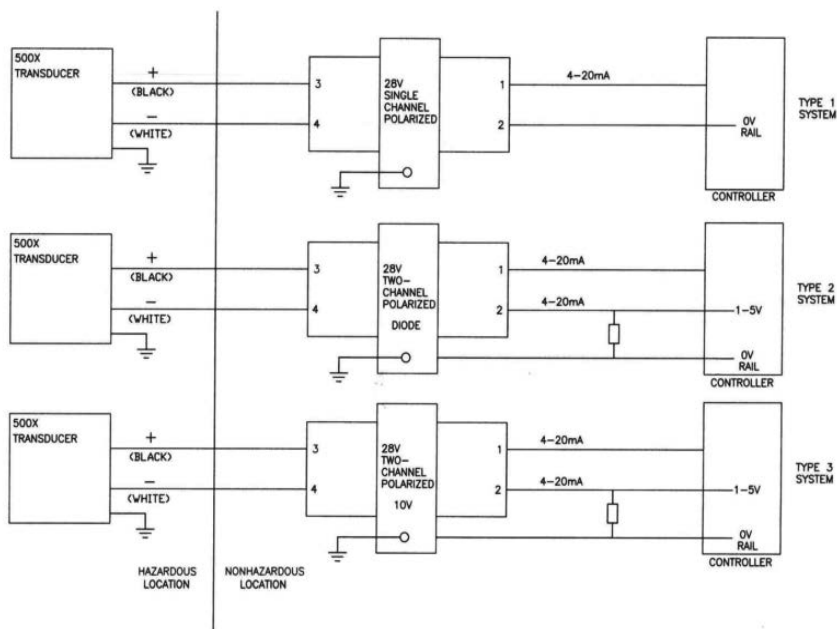

Drawing No. 431-990-013

NOTES:

- INSTALLATION TO BE IN ACCORDANCE WITH THE NATIONAL ELECTRIC CODE, NFPA 70, ARTICLE 504, AND ANSI/ISA RP 12.6.
- APPARATUS CONNECTED TO THE SYSTEM SHALL NOT USE OR GENERATE VOLTAGE GREATER THAN 250 V.
- INSTALL INTRINSICALLY SAFE BARRIERS IN ACCORDANCE WITH BARRIER INSTRUCTIONS.
- FACTORY MUTUAL APPROVED AS INTRINSICALLY SAFE FOR CLASS I, II, AND III, DIVISION 1, GROUPS C, D, E, F, AND G, WHEN INSTALLED AS SHOWN. UNITS WITH 'D' OPTION ARE FACTORY MUTUAL APPROVED AS INTRINSICALLY SAFE FOR CLASS I, DIVISION 1, GROUPS C, D WHEN INSTALLED AS SHOWN.
- FACTORY MUTUAL APPROVED AS NONINCENDIVE FOR CLASS I, DIVISION 2, GROUPS A, B, C, AND D, AND SUITABLE FOR CLASS II, DIVISION 2, GROUP F, G, AND CLASS III, DIVISION 1 AND 2. UNITS WITH 'D' OPTION ARE FACTORY MUTUAL APPROVED AS NONINCENDIVE FOR CLASS I, DIVISION 2, GROUPS A, B, C, D WHEN INSTALLED AS SHOWN. BARRIERS ARE NOT REQUIRED FOR NONINCENDIVE RATING. MAX V=30 VDC.
- CAUTION: SUBSTITUTION OF COMPONENTS MAY VOID FACTORY MUTUAL APPROVAL.
- AMBIENT TEMPERATURE RANGE: -30° C TO 60° C.
- FACTORY MUTUAL APPROVED AS INTRINSICALLY SAFE FOR CLASS I, II, AND III, DIVISION 1, GROUPS C, D, E, F, AND G WHEN USED ASSOCIATED APPARATUS. THE LINEAR BARRIER PARAMETERS MUST MEET THE FOLLOWING REQUIREMENTS:
 V_{oc} or $V_t < V_{max}$; $C_a > C_i + C_{cable}$
 I_{sc} or $I_t < I_{max}$; $L_a > L_i + L_{cable}$
 ENTITY PARAMETERS FOR MODEL 500 - A___
 $V_{max}=30V$ $C_i=0$
 $I_{max}=125mA$ $L_i=0mH$
 C_i IS CAPACITANCE CONTRIBUTED BY THE TRANSDUCER.
 L_i IS INDUCTANCE CONTRIBUTED BY THE TRANSDUCER.
- FOR DIN CONNECTOR OPTION, ADD D TO THE MODEL NUMBER.
- FOR NEMA 4X OPTION, ADD W TO THE MODEL NUMBER, ONLY THE STANDARD 1/2NPT CONDUIT MOUNTED IN A SUITABLE ENCLOSURE.
- MODELS WITH NEMA 4X OPTION ARE FACTORY MUTUAL APPROVED FOR INDOOR/OUTDOOR USE PER THE REQUIREMENTS OF NEMA 4X AS DESCRIBED IN THE NATIONAL ELECTRICAL MANUFACTURERS ASSOCIATION STANDARD NO. 250 "ENCLOSURES FOR ELECTRICAL EQUIPMENT, 1000 VOLTS MAX."

3. MAINTENANCE

Under normal circumstances, no maintenance should be required. If clean dry air is not used the orifice can become blocked. To clean, first turn off supply air, unscrew and remove orifice assembly (large silver screw head located above the out port). Then unplug orifice by using a wire that has a smaller diameter than 0.015 in. (0.38 mm). Use compressed air to blow out any loose particles inside the orifice assembly. Screw orifice assembly back into unit.

4. TROUBLESHOOTING

PROBLEM	CHECK
No output or low output	Zero adjustment Supply pressure too low Clogged orifice
Leakage	Connections
Low or improper span	Zero and Span adjustments Supply pressure too low Output leakage
Erratic operation	Electrical input signal Loose wires or connections Liquid in air supply

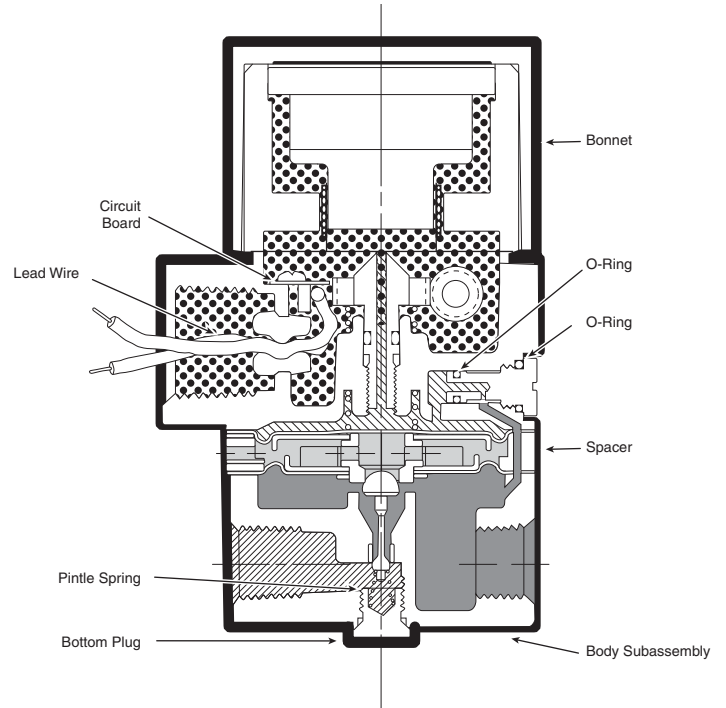

5. WARRANTY & DISCLAIMER

ControlAir, Inc. products are warranted to be free from defects in materials and workmanship for a period of eighteen months from the date of sale, provided said products are used according to ControlAir, Inc. recommended usages. ControlAir, Inc.'s liability is limited to the repair, purchase price refund, or replacement in kind, at ControlAir, Inc.'s sole option, of any products proved defective. ControlAir, Inc. reserves the right to discontinue manufacture of any products or change products materials, designs or specifications without notice.

WARNING These products are intended for use in industrial compressed-air systems only. Do not use these products where pressures and temperatures can exceed those listed under Specifications.

Before using these products with fluids other than air, for non-industrial application, life-support systems, or other applications not within published specifications, consult ControlAir, Inc.