

Type 595XP

Explosion Proof I/P Transducer

Installation, Operation and Maintenance Instructions

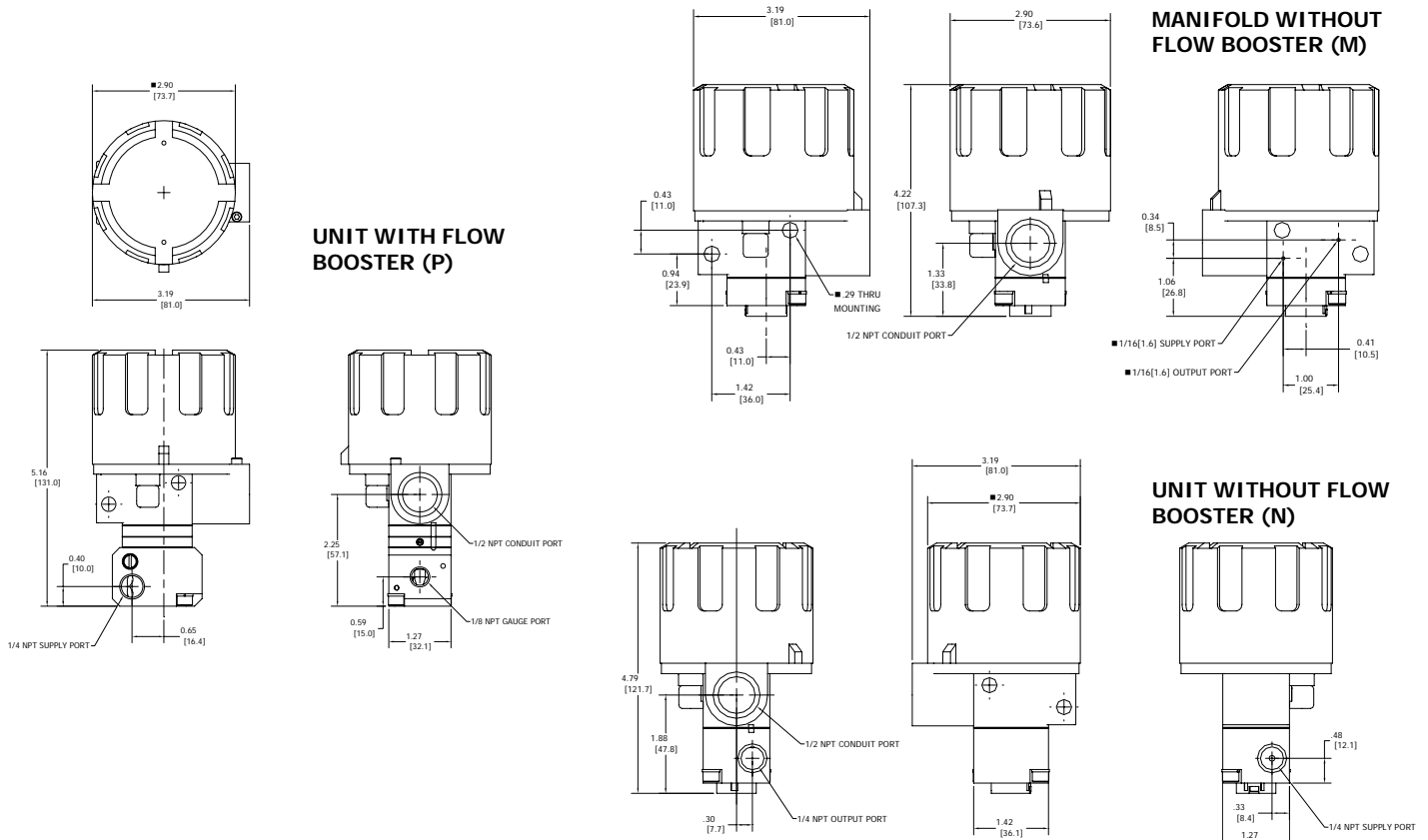

(Drawing downloads available at <http://www.controlair.com>)

Use this coding system to order:

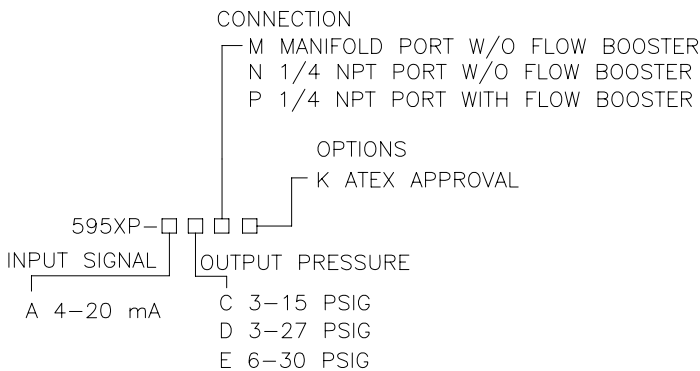

Contents

Section	Description	Page
1.0	Installation & Approvals	3
2.0	Operation	7
3.0	Maintenance	7
4.0	Troubleshooting	8
5.0	Warranty	8



8 Columbia Drive, Amherst, New Hampshire 03031 USA
 Phone: (603) 886-9400 ♦ Fax: (603) 889-1844
sales@controlair.com ♦ www.controlair.com

DANGER, WARNING, CAUTION and NOTE statements

DANGER

Refers to conditions or hazards which could result in serious personal injury or death.

WARNING

Refers to conditions or hazards which could result in personal injury.

CAUTION

Refers to conditions or hazards which could result in equipment or property damage.

NOTE

Alerts you to facts or special instructions.

ALL DANGER, WARNING, AND CAUTION NOTICES MUST BE COMPLIED WITH IN FULL.

SPECIFICATIONS

Functional Specifications	P Connection (with Flow Booster)	M & N Connection (without Flow Booster)
Input	4-20 mA	
Outputs	3-15 psig 0.20-1.0 BAR 3-27 psig 0.20-1.8 BAR 6-30 psig 0.40-2.0 BAR	
Air Consumption	0.1 scfm	2.00 scfh (0.06 m ³ /hr) @ 20 psig supply (1.4 BAR) 4.94 scfh (0.14 m ³ /hr) @ 85 psig supply (6.0 BAR) 8.36 scfh (0.24 m ³ /hr) @ 150 psig supply (10.0 BAR)
Supply Pressure Note: Supply pressure must be a minimum of 5 psig (0.3 BAR) above maximum output	3-15: 22 psig (1.5 BAR) max 3-27, 6-30: 42 psig (2.8 BAR) max	150 psig (10.0 BAR) max.
Flow Capacity	2.4 scfm (4.1 m ³ /hr) max.	Same as Air Consumption
Temperature Limits	-67°F to 185°F (-55°C to 85°C)	
Relative Humidity	75% average - 95% short time non-condensing	
Impedance	260 Ohms @ 70°F	
Loop Load	5.2 Volts @ 70°F	

Performance Specifications

Linearity (Independent)	<±0.5% of span	
Hysteresis	<±0.3% of span	
Deadband	<±0.1% of span	
Repeatability	<±0.3% of span; <±0.15% of span typical	
Mounting Orientation	<±0.5% / 90 degree change	
Air Supply Sensitivity	< .3% / 1.5 psig (0.10 BAR) change	<±0.6% / 25 psig (1.72 BAR) change
Vibration Effect	<±1% up to 10g and 20-80 Hz	
Temperature Effect	<±0.75% / 10°F change	

Physical Specifications

Housing	NEMA 4X (IP 65)	
Port Sizes	Pneumatic 1/4" NPT, & 1/16 manifold mount Electric 1/2" NPT, M20-1.5 (ATEX)	
Media	Clean, dry, oil-free, instrument air, filtered to 40 micron	
Electrical Connections	Terminal block	
Mounting	Direct (standard) or 2" pipe (optional)	
Materials	Housing: Chromate-treated aluminum with epoxy paint. NEMA 4X (IP65) Elastomers: Buna-N Trim: Stainless steel; brass; zinc-plated steel	
Weight	1.4 lb	

1. INSTALLATION AND APPROVALS

1.1 Pre-Installation Requirements

1.1.1 Environment: Suitable for installation in the following locations:

- Intrinsically safe operation in hazardous locations outdoors (NEMA 4X, CSA. ENC. 4 & IP65)
- Explosion Proof Installation in hazardous locations outdoors (NEMA 4X, CSA. ENC. 4 & IP65)
- See section 1.5, 1.6 and 1.7 for Factory Mutual (FM), Canadian Standards (CSA) and ATEX approvals.

WARNING

The I/P transducer enclosure contains aluminum and is considered to constitute a potential risk of ignition by impact or friction. Care must be taken into account during installation to prevent impact or friction.

DANGER

All wiring must be made to all local and national codes appropriate to the area of installation.

1.1.2 Electrical Input: 4-20 mA dc current source. It is recommended that shielded cable be used and that the shield be grounded to unit and earth ground. See Figure 1 on page 4 for location of ground screw.

1.1.3 Air supply: Clean, dry, oil free instrument air filtered to 40 micron.

NOTE

Clean all pipe lines to remove dirt and scale prior to installation. Failures attributable to instrument air supply contamination are not covered by the warranty.

1.1.4 For ATEX approved unit, customer must mark label by adding a tick mark in the appropriate box that corresponds to the type of hazardous area installation (i.e. Ex d, Ex ia, Ex nAnL or Ex nL). See Figure 2.

1.2 Mounting

1.2.1 The Type 595XP has been designed to mount inline, to a standard valve yoke, or to a 2" (5.1 cm) pipe (optional mounting kit 448-542-016 required).

1.3 Pneumatic Connections

1.3.1 Clean all pipe lines to remove dirt and scale prior to installation.

1.3.2 Supply air must be filtered to 40 microns and free of moisture and lubricants.

1.4 Electrical Connections

1.4.1 The Type 595XP is supplied with a 1/2" NPT electrical conduit connection as standard, M20 x 1.5 for ATEX option (see Figure 1).

1.4.2 A two (2) position terminal block that is wire ready is supplied for 22-12 AWG wire. Wire should be stripped approximately 1/4" before insertion. The terminals are labeled "+" and "-" on the terminal board (see Figure 1).

1.4.3 It is recommended that shielded cable be used and that the shield be grounded at the unit (ground screw provided) and to earth ground.

NOTE

Observe polarity. Reverse polarity will not damage the unit, but unit will not operate.

CAUTION

Conduit should be connected to prevent condensation from collecting in the unit.

Figure 1

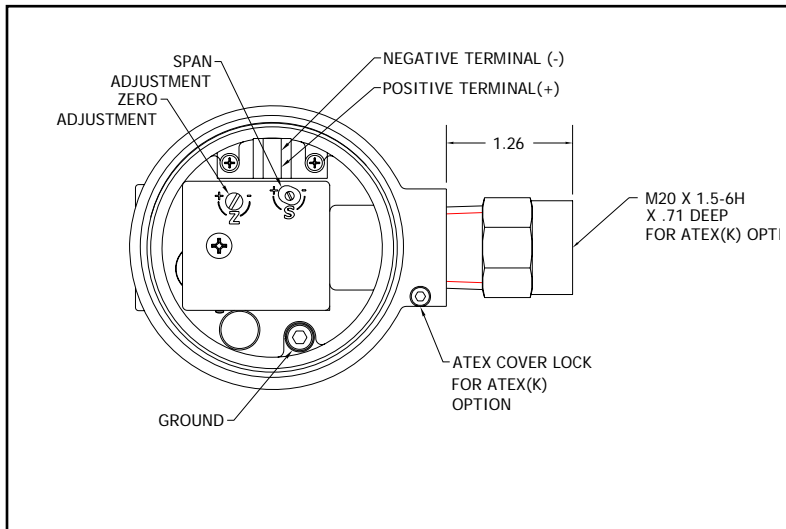
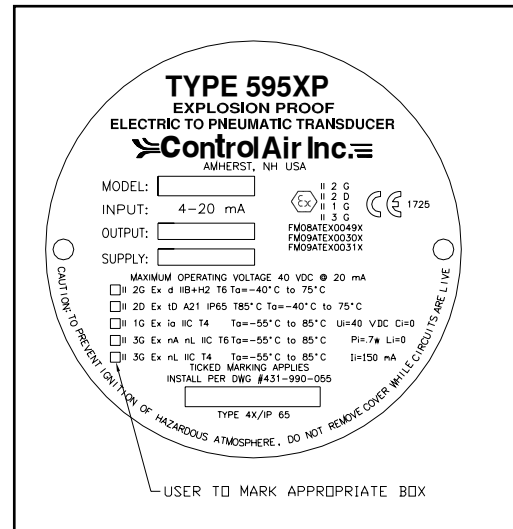

Figure 2



1.5 FM Approvals (FM) & Canadian Standards Association (CSA) Approvals



Intrinsically Safe:

- Class I, Div. 1, Groups A, B, C & D
- Class II, Div. 1, Groups E, F & G
- Class III, Div. 1, Fibers
- Enclosure Nema 4X (IP65)
- Rated 4-20 mA, 40 VDC Max.
- Temp. Code T4 Ta = + 70⁰ C

Non-Incendive:

- Class I, Div. 2, Groups A, B, C & D
- Class II, Div. 2, Groups E, F & G
- Class III, Div. 2, Fibers
- Enclosure Nema 4X (IP65)
- Temp. Code T6

Explosion Proof:

- Class I, Div. 1, Groups A, B, C & D
- Enclosure Nema 4X (IP65)
- Temp. Code T6

Entity Parameters:

- V_{max} = 40 VDC Ci = 0 uF
- I_{max} = 150 mA Li = 0 mH

Dust Ignition Proof:

- Class II & III, Div. 1, Groups E, F & G
- Enclosure Nema 4X (IP65)
- Temp. Code T6

Entity Installation Requirements:

- V_{max} ≥ V_t OR V_{oc}
- I_{max} ≥ I_t OR I_{sc}
- C_a ≥ C_i + C_{cable}
- L_a ≥ L_i + L_{cable}

Note: Cable capacitance and inductance must be considered when connecting to pressure transducer.

1.6 ATEX Approvals (Option K)

Entity Parameters:

U_i (V_{max}) = 40 VDC C_i = 0 μ F
 I_i (I_{max}) = 150 mA L_i = 0 mH
 P_i = .7 W Max.



II 1G
 II 3G
 II 2G
 II 2D



ATEX(FM)

FM09ATEX0030X II 1 G Ex ia IIC T4* T_a = -55°C TO +85°C
 FM09ATEX0031X II 3 G Ex nL IIC T4* T_a = -55°C TO +85°C
 FM09ATEX0031X II 3 G Ex nA nL IIC T6** T_a = -55°C TO +85°C

* SEE ENERGY LIMITING PARAMETERS TABLE BELOW

** T6 TEMPERATURE CLASS FOR SELF PROTECTED ENERGY LIMITED APPARATUS, THE 4-20 mA INPUT VOLTAGE OF 40Vdc.

ENERGY LIMITING PARAMETERS

TEMP. CLASS	T_a	I_i	U_i	P_i
T6	60° C	50 mA	42.5 V	2.125 W
T6	55° C	60 mA	38.8 V	2.328 W
T5	70° C	60 mA	38.8 V	2.328 W
T5	55° C	100 mA	30.0 V	3.0 W
T5	45° C	120 mA	28.0 V	3.36 W
T4	85° C	60 mA	38.8 V	2.328 W
T4	85° C	100 mA	30.0 V	3.0 W
T4	80° C	120 mA	28.0 V	3.36 W
T4	70° C	150 mA	25.5 V	3.825 W
T5	85° C	23 mA	6.75 V	0.155 W

ATEX (FM) Flame proof

FM 08ATEX0049X II 2 G Ex d IIB + H2 T6 T_a = -40° C to +75° C
 II 2 D Ex tD A21 IP65 T 85° C T_a = -40° C to +75° C

1.7 EC Declaration of Conformity

We, ControlAir, Inc.
 8 Columbia Drive
 Amherst, NH 03031



Declare that the Type 595XP Transducer family to which this declaration applies, comply with these standards:

EN 50082-1:1998

EN 55011:1999

EN 61010-1:1993 including AMD2:1995

Following the provisions of EMC directive 89/336/EEC

EN 60079-0:2006

EN 60079-11:2007

EN 60079-26:2007

EN 60079-1:2007

EN 61241-0:2007

EN 61241-1+Corr.1:2004/2005

EN 60529+A1,A2:1992/2000

EN 60079-15:2005

Following the provisions of EMC directive 94/9/EC

1.8 INSTALLATION DRAWING NO. 431-990-055

- (North America) Control equipment connected to the Associated Apparatus must not use or generate more than 250 Vrms or Vdc.
- (North America) The IS Barriers or Equipment (Associated Apparatus) must be FM Approved and CSA certified and the configuration of associated Apparatus must be FM Approved and CSA certified under the Entity Concept. The Associated Apparatus may be installed within the Hazardous (Classified) location for which it is certified. The Associated Apparatus and hazardous location loop apparatus manufacturer's control drawings must be followed when installing this equipment. An AEx [ib] Associated Apparatus is suitable only for connection to Class I, Zone 1, Hazardous (Classified) Locations and is not suitable for Class I, Zone 0, or Class I, Division 1 Hazardous (Classified) Locations.

(ATEX) The IS Barriers or other Associated Apparatus shall comply with the ATEX directive 94/9/EC.
- (US) Installation should be in accordance with ANSI/ISA RP12.06.01 "Installation of Intrinsically Safe Systems for Hazardous (Classified) Locations" and Article 500 of the National Electrical Code (ANSI/NFPA 70)

(Canada) Installation should be in accordance with Section 18 of the Canadian Electrical Code.

(ATEX) Installation shall be in accordance with the applicable local installation rules Energy Limitation Parameters specified.
- (North America) All units suitable for Type 4X installations.
- (North America) Units are suitable for Class I, Division 2, Groups A, B, C, and D hazardous (classified) locations. Transducers to be installed in accordance with the

(US) National Electrical Code (ANSI/NFPA 70) Division 2 hazardous (classified) location wiring techniques

(Canada) Canadian Electrical Code.
- The Intrinsic Safety Entity concept allows the interconnection of two Intrinsically safe devices with entity parameters not specifically examined in combination as a system when:

Entity Parameters for: MODELS TYPE 595	U_i or $V_{max} > U_o$ or V_{oc}
U_i (V_{max}) = 40 V	I_i or $I_{max} > I_o$ or I_{sc} or I_t
I_i (I_{max}) = 150 mA	C_a or $C_o > C_i + C_{cable}$
$C_i = 0$	L_a or $L_o > L_i + L_{cable}$
$L_i = 0$	$P_i > P_o$
$P_i = 0.7$ watts	
- No revision to this drawing is permitted without prior FM Approval and CSA Certification.

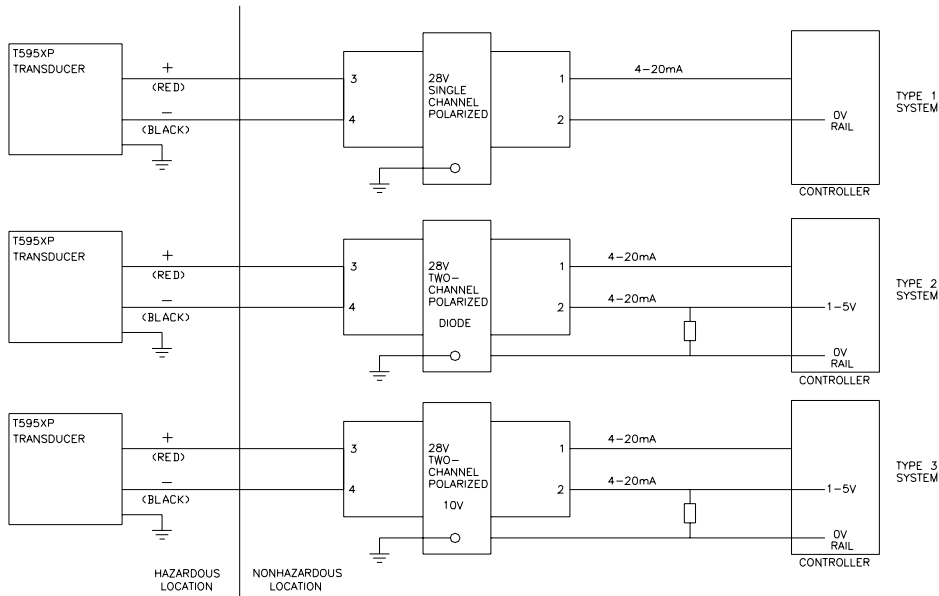

431-990-055

2. OPERATION

2.1 Calibration

2.1.1 All units are shipped from the factory calibrated, direct acting.

NOTE

Factory calibration is susceptible to shift due to handling during transit. ControlAir recommends that all units be recalibrated prior to use.

2.1.2 Though the units are shipped fully calibrated it is suggested that the user check the calibration to ensure that settings and operation match the application requirements.

NOTE

ATEX option units come with a factory installed cover lock screw. Screw must be removed before removing cover. Screw must be replaced upon replacing cover. See Figure 1, Section 1.4

NOTE

It is not necessary to remove the plastic cover of the unit for calibration.

2.2 Calibration

2.2.1 In direct acting operation the unit is calibrated so that minimum input signal corresponds to minimum output pressure and increasing input signal results in increasing output pressure.

2.2.2 Apply the minimum input signal of the range being used (e.g. 4 mA).

2.2.3 Observe the output pressure. If necessary, adjust the zero screw until reaching minimum output pressure setting. Turn zero screw clockwise to increase and counter clockwise to decrease.

2.2.4 Apply the maximum input signal of the range being used (e.g. 20 mA).

2.2.5 Observe the output pressure. If necessary, adjust the span screw until reaching maximum output pressure setting. Turn span screw clockwise to increase pressure, counter clockwise to decrease pressure.

2.2.6 After setting the span it will be necessary to recheck the zero. Repeat steps 1-4 until both end points are at required values.

3. MAINTENANCE AND REPAIRS

NOTE

Under normal circumstances, no maintenance should be required.

3.1 Instrument Air Filtration

3.1.1 Failures due to instrument supply air contamination are not covered by warranty.

3.1.2 Use of oil and/or water saturated instrument air can cause erratic operation.

3.1.3 Poor quality instrument air can result in unit failure. It is recommended that a filter regulator (such as ControlAir Type 300) be placed upstream of each unit where oil and/or water laded instrument air is suspected.

3.2 Factory Repairs

3.2.1 In the event of unit failure, the Type 595XP can be returned to the factory through point of purchase for warranty repair if the warranty period has not expired.

3.2.2 All units returned for repair must be authorized prior to receipt at the factory. Contact a representative at the point of purchase to receive a Return Authorization Number.

3.3 Field Repairs

3.3.1 Service kits for elastomer components in the Type 595XP are available. Consult factory for kit numbers and availability.

3.3.2 Replacement components for the Type 595XP are available. Consult factory for part numbers and availability.

3.4 Filter Replacement

3.4.1 Supply pressure can become obstructed should the felt filter element become clogged. To replace filter (P/N: 445-777-018), remove slotted plug and carefully remove filter using tweezers. Insure no dust or dirt particles remain in filter chamber. Insert new filter into chamber in orientation as shown in figure 3. Replace slotted plug, insuring o-ring is properly seated. For N-connection, remove Nema cap screw using a 5/64 hex key.

Figure 3 – Replacing Filter



4. TROUBLESHOOTING

PROBLEM	LOOK FOR	SOLUTION
No or low output	Wires reversed Zero adjustment Clogged filter Supply pressure too low	Reverse input wires (see Figure 1) Reset zero (2.2.3) Replace filter (see Figure 3) Increase supply pressure (see specs)
Unstable / low output	Electrical connection	Check connection/signal (1.1.2)
Erratic operation	Liquid/contamination in air supply Supply pressure	Clean air supply (1.1.3) Verify supply pressure (see specs)
Output equals supply pressure	Improper pneumatic connections	Insure that supply is connected to "IN" port and output is connected to "OUT" port (1.3.3, 1.3.4)

NOTE

If problems are not solved by troubleshooting procedures, contact a factory applications engineer at (603) 886-9400 for further assistance.

5. WARRANTY & DISCLAIMER

ControlAir, Inc. products are warranted to be free from defects in materials and workmanship for a period of eighteen months from the date of sale, provided said products are used according to ControlAir, Inc. recommended usages. ControlAir, Inc.'s liability is limited to the repair, purchase price refund, or replacement in kind, at ControlAir, Inc.'s sole option, of any products proved defective. ControlAir, Inc. reserves the right to discontinue manufacture of any products or change products materials, designs or specifications without notice. Note: ControlAir does not assume responsibility for the selection, use, or maintenance of any product. Responsibility for the proper selection, use, and maintenance of any ControlAir product remains solely with the purchaser and end user.

WARNING

These products are intended for use in industrial compressed-air systems only. Do not use these products where pressures and temperatures can exceed those listed under

Before using these products with fluids other than air, for non-industrial application, life-support systems, or other applications not within published specifications, consult ControlAir, Inc.