

Type 550X

Miniature I/P, E/P Transducer

Installation, Operation and Maintenance Instructions

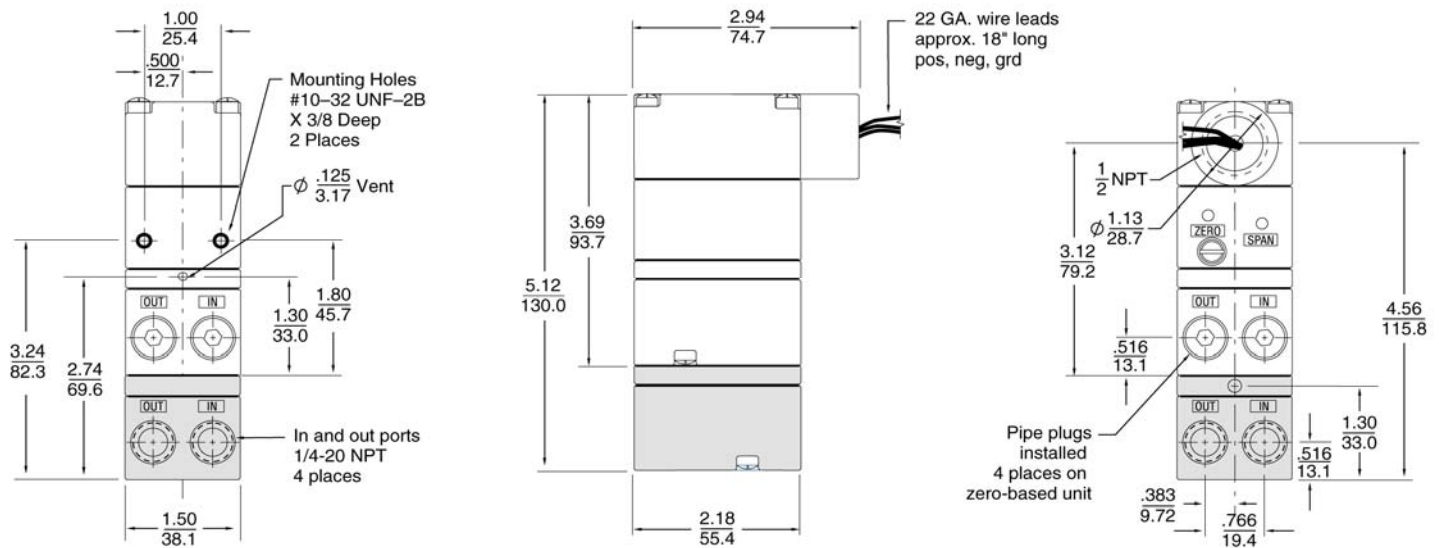

Shaded areas and associated dimensions apply to the zero based unit only.

(Drawing downloads available at <http://www.controlair.com>)

Contents

Section	Description	Page
1.0	Installation	3
2.0	Operation	5
3.0	Approvals	6
4.0	Maintenance & Repairs	7
5.0	Troubleshooting	8
6.0	Warranty	8



8 Columbia Drive, Amherst, New Hampshire 03031 USA
 Phone: (603) 886-9400 ♦ Fax: (603) 889-1844
 sales@controlair.com ♦ www.controlair.com

DANGER, WARNING, CAUTION and NOTE statements

DANGER

Refers to conditions or hazards which could result in serious personal injury or death.

WARNING

Refers to conditions or hazards which could result in personal injury.

CAUTION

Refers to conditions or hazards which could result in equipment or property damage.

NOTE

Alerts you to facts or special instructions.

ALL DANGER, WARNING, AND CAUTION NOTICES MUST BE COMPLIED WITH IN FULL.

SPECIFICATIONS

Functional Specifications

	Standard Range			High Output		Zero-Based		
Input	4-20 mA, 0-5 VDC, 0-10 VDC, 1-5 VDC, 1-9 VDC							
Outputs psig (BAR)	3-15 (0.2-1.0)	3-27 (0.2-1.8)	6-30 (0.4-2.0)	2-60 (0.14-4.0)	3-120 (0.2-8.0)	0-30 (0.0-2.0)	0-60 (0.0-4.0)	0-120 (0.0-8.0)
Supply Pressure psig (BAR)	18-100 (1.2-6.9)	30-100 (2.0-6.9)	33-100 (2.5-6.9)	63-150 (4.2-10.0)	123-150 (8.3-10.0)	33-100 (2.5-6.9)	63-100 (4.3-6.9)	123-150 (8.4-10)
Air Consumption	1.8 scfh (0.05 m3/hr) at mid range typical			4.2 scfh at mid range typical		6.0 scfh at mid range typical		
Flow Capacity	4.5 scfm (7.7 m3/hr) at 25 psig (1.7 BAR) supply pressure 12.0 scfm (20.0 m3/hr) at 100 psig (6.9 BAR) supply pressure			12.0 scfm (20.0 m3/hr) at 100 psig (6.9 BAR) supply	20.0 scfm (24.0 m3/hr) at 150 psig (10.0 BAR) supply	12.0 scfm (20.0 m3/hr) at 100 psig (6.9 BAR) supply		20.0 scfm (34.0 m3/hr) at 150 psig (10.0 BAR) supply
Temperature Limits	-40°F to 158°F (-40°C to +70°C)							
Impedance	4-20 mA 180 Ohms 0-5 VDC 615 Ohms 0-10 VDC 1230 Ohms 1-5 VDC 495 Ohms 1-9 VDC 985 Ohms	4-20 mA 240 Ohms 0-5 VDC 550 Ohms 0-10 VDC 1100 Ohms 1-5 VDC 440 Ohms 1-9 VDC 880 Ohms	4-20 mA 240 Ohms 0-5 VDC 550 Ohms 0-10 VDC 1100 Ohms 1-5 VDC 440 Ohms 1-9 VDC 880 Ohms	4-20 mA 245 Ohms 0-5 VDC 520 Ohms 0-10 VDC 1040 Ohms 1-5 VDC 495 Ohms 1-9 VDC 900 Ohms	4-20 mA 280 Ohms 0-5 VDC 500 Ohms 0-10 VDC 1000 Ohms 1-5 VDC 475 Ohms 1-9 VDC 880 Ohms	4-20 mA 290 Ohms 0-5 VDC 450 Ohms 0-10 VDC 900 Ohms 1-5 VDC 410 Ohms 1-9 VDC 830 Ohms	4-20 mA 300 Ohms 0-5 VDC 480 Ohms 0-10 VDC 960 Ohms 1-5 VDC 460 Ohms 1-9 VDC 800 Ohms	4-20 mA 315 Ohms 0-5 VDC 495 Ohms 0-10 VDC 990 Ohms 1-5 VDC 455 Ohms 1-9 VDC 785 Ohms

Performance Specifications

Linearity (Independent)	<± 0.5% of span	<± 2.0% of span	<± 1.5% of span
Hysteresis, and Repeatability	< 0.5% of span	< 0.5% of span	< 1.0% of span
Supply Pressure Sensitivity	< 0.1% of span per 1.0 psig (0.07 BAR)	< 0.4% of span per 1.0 psig (0.07 BAR)	< 0.02% of span per 1.0 psig (0.07 BAR)

Physical Specifications

Port Sizes	Pneumatic: 1/4" NPT	
Media	Clean, dry, oil-free, instrument air, filtered to 40 micron	
Electrical Connections	Conduit 1/2" NPT, Terminal Block, DIN 43650	
Mounting	Direct wall, panel, 1 1/2" pipe, DIN rail or Manifold	
Materials	Housing: Elastomers: Trim:	Chromate-treated aluminum with epoxy paint. NEMA 4X (IP65) Buna-N Stainless steel; brass; zinc-plated steel
Weight	1.3 lbs (0.59 kg)	1.7 lbs (0.77 kg)

1. INSTALLATION

1.1 Pre-Installation Requirements

1.1.1 Environment: Suitable for installation in the following locations:

- Intrinsically safe operation in hazardous locations outdoors (NEMA 4X, CSA.ENC.4 & IP65)
- See section 3.1, 3.2 and 3.3 for Factory Mutual (FM), Canadian Standards (CSA), ATEX and EC approvals.

DANGER

All wiring must be made to all local and national codes appropriate to the area of installation.

1.1.2 Electrical Input: 4-20 mAdc current source or 0-5, 0-10, 1-5, 1-9 VDC voltage source depending on model.

1.1.3 Air supply: Clean, dry, oil free instrument air filtered to 40 micron.

NOTE

Clean all pipe lines to remove dirt and scale prior to installation. Failures attributable to instrument air supply contamination are not covered by the warranty.

CAUTION

This instrument vents to atmosphere. The use of supply gas other than air can create a hazardous environment.

1.2 Mounting

1.2.1 The Type 550X has a standard mounting kit that enables 1 ½" pipe, panel or wall mounting of the unit.

1.2.2 To mount unit to a 1 ½" pipe, use two 10-32 holes on the back of the unit to attach bracket to transducer. Then place U-bolt around pipe and through bracket. Place nuts on U-bolt and tighten (see figure 1).

1.2.3 With access to the rear of a panel, attach transducer using two 10-32 screws and the two threaded mounting screws on the back of the unit. With no access to the back of the panel, attach the bracket to the transducer using the two 10-32 holes on the back of unit and mount bracket to panel using four 10-32 screws (see figure 2).

1.2.4 Due to it's light weight, the Type 550X can also be mounted in line with support provided by the supply and output piping.

1.2.5 Because of it's small size, the Type 550X can easily be mounted to a manifold. ControlAir's Type 925 multifunction supply manifold is designed for this purpose.

Figure 1 - Pipe Mounting Figure 2 - Panel Mounting

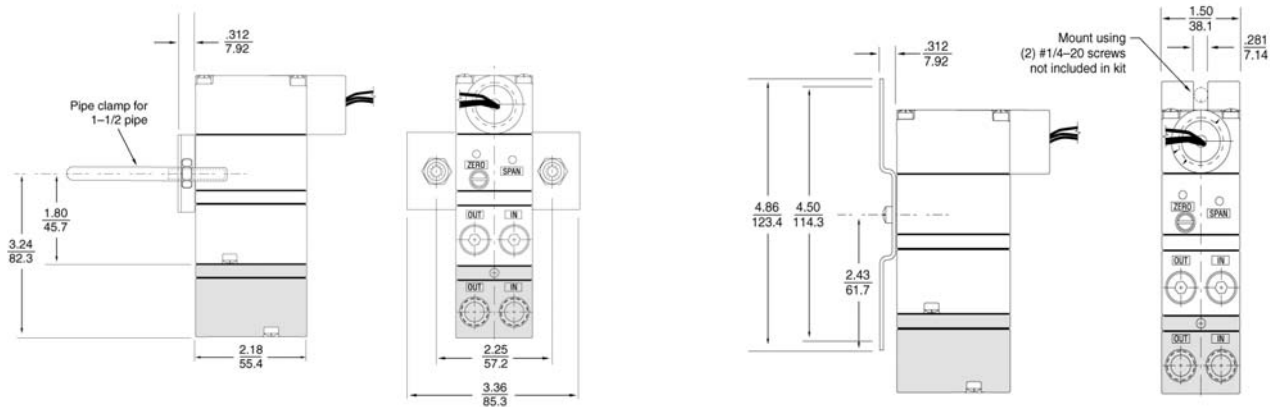

Shaded areas and associated dimensions apply to the zero based unit only.

1.2.6 The Type 550X can be mounted to DIN-rail using the optional kit, ControlAir part number 445-766-024. This will allow the transducer to mount to DIN 50045, 50035, 50022 rails (see figure 3).

Figure 3 - DIN Rail mounting kit 445-766-024

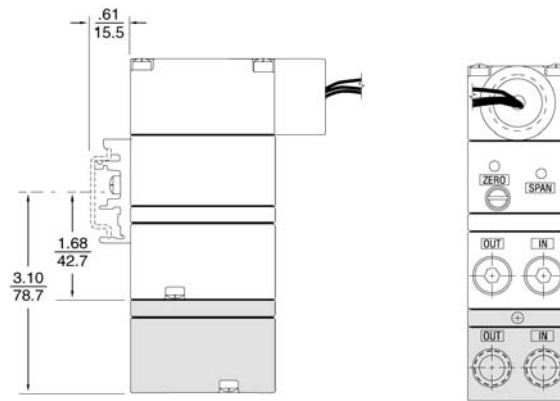

Shaded areas and associated dimensions apply to the zero based unit only.

1.3 Pneumatic Connections

- 1.3.1 Clean all pipe lines to remove dirt and scale prior to installation.
- 1.3.2 Supply air must be filtered to 40 microns and free of moisture and lubricants.
- 1.3.3 Two (2) 1/4" NPT ports labeled IN are provided for supply air connections. Either port may be used. The unused port must be plugged with the pipe plug included with the unit.
- 1.3.4 Two (2) 1/4" NPT ports labeled OUT are provided for pneumatic output connections. Either port may be used and one may be used for the mounting of an output gauge. If no gauge is installed, the unused port must be plugged with the pipe plug included with the unit.

1.4 Electrical Connections

- 1.4.1 Both the I/P and E/P versions of the Type 550X are two wire devices (do not require a separate power source), plus a safety ground. The I/P unit requires a variable input current of 4-20 mA. The E/P version requires a DC voltage input signal such as 0-10 VDC.
- 1.4.2 1/2" NPT conduit connection (A) is made using 18" pigtail wire coming from unit. For I/P (current to pressure) versions, electrical connections are made to the red (+) and black (-) leads. The green lead is furnished for case ground. For E/P (voltage to pressure) versions, electrical connections are made to the red (+) and black (-). The green lead is furnished for case ground (see figure 4).

Figure 4 - 1/2" Conduit Connection

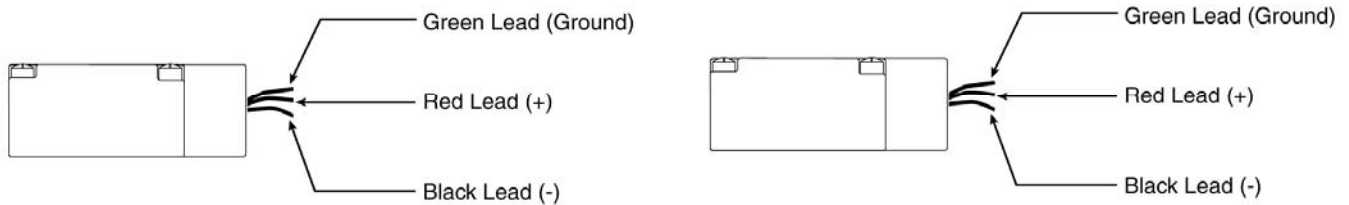

I/P Conduit Connection

E/P Conduit Connection

1.4.3 **DIN 43650 Connector (D)** electrical connections are made as shown in figure 5.

Figure 5 - DIN 43650 Connections

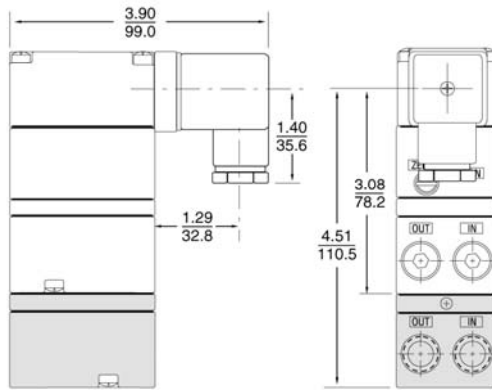

Terminal	I/P Connection	E/P Connection
1	Positive (+)	Positive (+)
2	Negative (-)	Negative (-)
3	Not Used	Not Used
⊥	Ground (⊥)	Ground (⊥)

Shaded areas and associated dimensions apply to the zero based unit only.

1.4.4 Terminal Block (T) Electrical connections are made to the positive (+) and negative (-) terminals. For direct acting operation connect the positive side of the input signal to the (+) terminal

1.4.5 The use of shielded cable is recommended.

Figure 6 - Terminal Block Connections

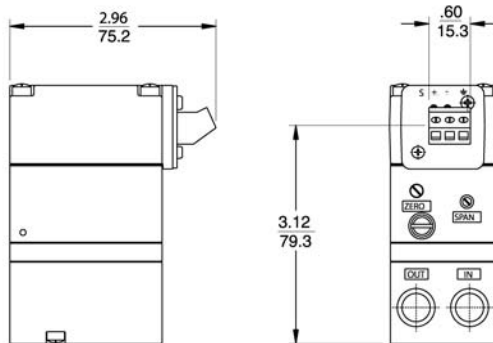

Terminal	I/P-E/P Connection
+	Positive (+)
-	Negative (-)
S	Not Used
⊥	Ground (⊥)

2. OPERATION

2.1 Calibration

2.1.1 All units are shipped from the factory calibrated, direct acting.

NOTE

Factory calibration is susceptible to shift due to handling during transit. ControlAir recommends that all units be recalibrated prior to use.

2.1.2 Though the units are shipped fully calibrated it is suggested that the user check the calibration to ensure that settings and operation match the application requirements.

NOTE

The unit must be calibrated in the plane it is mounted in.

NOTE

Repeated cycling of supply pressure may cause increased leakage and premature product failure.

2.2 Direct Acting Calibration

2.2.1 In direct acting operation the unit is calibrated so that minimum input signal corresponds to minimum output pressure and increasing input signal results in increasing output pressure.

- 2.2.2 Apply the minimum input signal of the range being used (e.g. 4 mA for a 4-20 mA unit).
- 2.2.3 Observe the output pressure. If necessary, adjust the zero screw until reaching minimum output pressure setting. Turn zero screw clockwise to increase and counter clockwise to decrease.

NOTE *If unable to achieve output during the calibration process, follow the steps outlined in .1.4. to clean the orifice. Then turn the zero adjustment screw clockwise slowly and carefully until output pressure begins to respond.*

- 2.2.4 Apply the maximum input signal of the range being used (e.g. 20 mA for a 4-20 mA unit).
- 2.2.5 Observe the output pressure. If necessary, adjust the span screw until reaching maximum output pressure setting.

NOTE *For I/P (current) input models, turn span screw clockwise to increase pressure, counter clockwise to decrease pressure. For E/P (voltage) input models, turn span screw clockwise to decrease pressure, counter clockwise to increase pressure.*

- 2.2.6 After setting the span it will be necessary to recheck the zero. Repeat steps 1-4 until both end points are at required values.

2.3 Reverse Acting Calibration

- 2.3.1 In reverse acting operation the unit is calibrated so that minimum input signal corresponds to maximum output pressure and increasing the input signal will decrease output pressure.
- 2.3.2 For reverse acting operation first interchange the signal leads so that black is now positive and red is negative.
- 2.3.3 Adjust the zero screw with minimum input signal to set maximum pressure output. Clockwise will increase pressure. Adjust the span screw with maximum input signal to set the minimum pressure output. Counter clockwise will decrease pressure. Repeat as necessary.

3. APPROVALS

3.1 Factory Mutual Research Corporation (FM) & Canadian Standards (CSA) Approvals



Intrinsically Safe (1/2" NPT Conduit):

Class I, II, III, Division 1,
Groups C, D, E, F & G
Enclosure Nema 4X (IP 65)
Temp. Code T4 Ta = 70⁰ C
Rated 4-20 mA, 30 VDC Max.

Intrinsically Safe (1/2" NPT Conduit):

Class I, Division 2,
Groups A, B, C & D
Temp. Code T4 Ta = 70⁰ C

Intrinsically Safe (DIN & Terminal)

Class I, Division 1, Groups C & D
Temp. Code T4 Ta=70⁰ C
Rated 4-20 mA, 30 VDC Max.

Suitable for (Conduit only)

Class II & III, Division 2
Groups F & G
Temp. Code T4 Ta = 70⁰ C

Entity Parameters

Ui (Vmax) = 30 VDC Ci = 0 uF
Ii (Imax) = 125 mA Li = 0 m H
Pi = .7 w Max.

3.2 ATEX Approvals (option K)

Ex ia IIB T4
Tamb = -40⁰ C to +70⁰ C
FM09ATEX0012X

Entity Parameters
Ui (Vmax) = 30 VDC Ci = 0 uF
Ii (Imax) = 125 mA Li = 0 mH
Pi = .7 w Max.



INSTALLATION DRAWING NO. 431-990-036

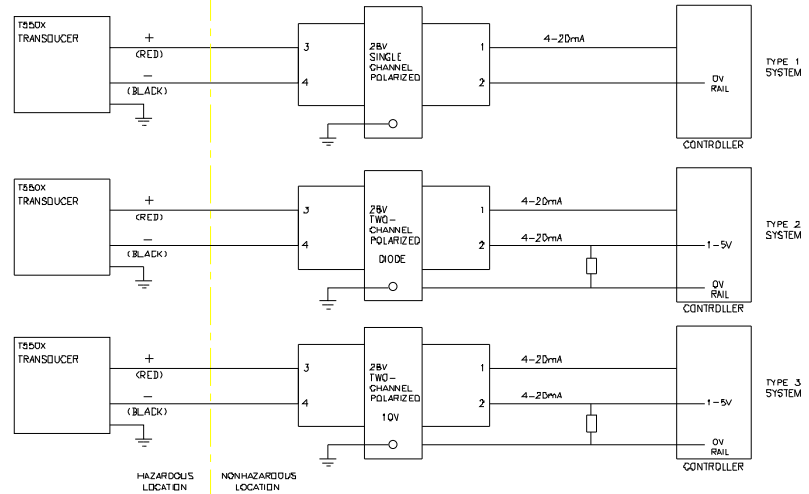
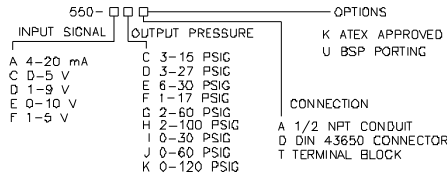

Notes:

- (North America) Control equipment connected to the Associated Apparatus must not use or generate more than 250 Vrms or Vdc.
- The IS Barriers or Equipment (Associated Apparatus) must be FM Approved and the configuration of associated Apparatus must be FM Approved and CSA certified under the Entity Concept. The Associated Apparatus may be installed within the Hazardous (Classified) location for which it is approved. The Associated Apparatus and hazardous location loop apparatus manufacturer's control drawings must be followed when installing this equipment. An AEx [ib] Associated Apparatus is suitable only for connection to Class I, Zone 1, Hazardous (Classified) Locations and is not suitable for Class I, Zone 0, or Class I, Division 1 Hazardous (Classified) Locations.
(ATEX) The IS barriers or other Associated Apparatus shall comply with the ATEX directive 94/9/EC. Control equipment connected to the Associated Apparatus shall not use or generate more than the marked Um.
- (US) Installation should be in accordance with ANSI / ISA RP12.6 "Installation of Intrinsically Safe Systems for Hazardous (Classified) Locations" and Article 500 of the National Electrical Code (ANSI/NFPA 70).
(Canada) Installation should be in accordance with Section 18 of the Canadian Electrical Code.
(ATEX) Installations shall comply with EN 60079-14
- (North America) The connection option "A" is suitable for Type 4X installations. All others must be mounted in a suitable enclosure.
- The connection option "A" is suitable for Class I, II, and III, Division 2, Groups A, B, C, D, E, F, and G hazardous (classified) locations. Dust-tight conduit seal must be used when installed in Class II and Class III environments. The connection options "D" and "T" are suitable for Class I, Division 2, Groups A, B, C, and D hazardous (classified) locations.
Transducers to be installed in accordance with the:
(US) National Electrical Code (ANSI--NFPA 70) Division 2 hazardous (classified) location wiring techniques. (Canada) Canadian Electrical Code
- The Intrinsic Safety Entity concept allows the interconnection of two FM Approved Intrinsically safe devices with entity parameters not specifically examined in combination as a system when:
 U_i or $V_{max} > U_o$ or V_{oc} or $V_t > 7.2$ volts
 I_i or $I_{max} > I_o$ or I_{sc} or I_t
 C_a or $C_o > C_i + C_{cable}$
 L_a or $L_o > L_i + L_{cable}$
 $P_i > P_o$.
 Entity Parameters for: MODELS T550-A*%
 $U_i (V_{max}) = 30$ V
 $I_i (I_{max}) = 125$ mA
 $P_i = 0.70$ watts
 $C_i = 0$ uF
 $L_i = 0$ mH
- No revision to this drawing is permitted without prior FM Approvals notification.
- The Intrinsic Safety Entity concept allows the interconnection of two EC-Type certified devices with entity parameters, not specifically examined in a combination when:
 $I_i > I_o$
 $C_a > C_i + C_{cable}$
 $L_a > L_i + L_{cable}$
 $P_i > P_o$
- Because the enclosure is made of aluminum, if it is mounted in an area where the use of category 1G apparatus is required, it must be installed such that even in the event of rare incidents, ignition sources due to impact and friction sparks are excluded.

3.3 EC Declaration of Conformity



We, ControlAir, Inc.
8 Columbia Drive
Amherst, NH 03031

Declare that the Type 550X Transducer family to which this declaration applies, comply with these standards:

EN 50082-1:1998
EN 55011:1999
EN 61010-1:1993 including AMD2:1995
Following the provisions of EMC directive 89/336/EEC

EN60079-0, EN60079-11, EN60079-26
Following the provisions of EMC Directive 94/9/EC

4. MAINTENANCE AND REPAIRS

NOTE

Under normal circumstances, no maintenance should be required.

4.1 Instrument Air Filtration

- 4.1.1 Failures due to instrument supply air contamination are not covered by warranty.
- 4.1.2 Use of oil and/or water saturated instrument air can cause erratic operation.
- 4.1.3 Poor quality instrument air can result in unit failure. It is recommended that a filter regulator (such as ControlAir Type 300) be placed upstream of each unit where oil and/or water laded instrument air is suspected.
- 4.1.4 If clean, dry air is not used the orifice can become blocked. To clean, first turn off supply air, then remove the screw located on the side of the unit above the "out" port. The orifice is a very small hole on the side of the screw. Unplug the orifice using a wire that has a smaller diameter than 0.012" (0.30mm). Replace screw tightly into unit.

4.2 Factory Repairs

- 3.2.1 In the event of unit failure, the Type 550X can be returned to the factory through point of purchase for warranty repair if the warranty period has not expired.
- 3.2.2 All units returned for repair must be authorized prior to receipt at the factory. Contact a representative at the point of purchase to receive a Return Authorization Number.

4.3 Field Repairs

- 3.3.1 Service kits for elastomer components in the Type 550X are available. Consult factory for kit numbers and availability.
- 3.3.2 Replacement components for the Type 550X are available. Consult factory for part numbers and availability.

5. TROUBLESHOOTING

PROBLEM	LOOK FOR	SOLUTION
No or low output	Zero adjustment Supply pressure too low	Reset zero (2.2.2 and 2.2.3) Increase supply pressure (see specs)
Unstable / low output	Electrical connection Clogged orifice	Check connection/signal (1.4) Clean orifice (4.1.3)
Erratic operation	Liquid/contamination in air supply	Clean air supply (1.1.3)
Works in reverse	Pressure goes down when signal is increased	Reverse input wires (1.4.2)
Output equals supply pressure	Improper pneumatic connections	Insure that supply is connected to "IN" port and output is connected to "OUT" port (1.3.3, 1.3.4)

NOTE

If problems are not solved by troubleshooting procedures, contact a factory applications engineer at (603) 886-9400 for further assistance.

6. WARRANTY & DISCLAIMER

ControlAir, Inc. products are warranted to be free from defects in materials and workmanship for a period of eighteen months from the date of sale, provided said products are used according to ControlAir, Inc. recommended usages. ControlAir, Inc.'s liability is limited to the repair, purchase price refund, or replacement in kind, at ControlAir, Inc.'s sole option, of any products proved defective. ControlAir, Inc. reserves the right to discontinue manufacture of any products or change products materials, designs or specifications without notice. Note: ControlAir does not assume responsibility for the selection, use, or maintenance of any product. Responsibility for the proper selection, use, and maintenance of any ControlAir product remains solely with the purchaser and end user.

WARNING

These products are intended for use in industrial compressed-air systems only. Do not use these products where pressures and temperatures can exceed those listed under Specification

Before using these products with fluids other than air, for non-industrial application, life-support systems, or other applications not within published specifications, consult ControlAir, Inc.



8 Columbia Drive
Amherst, NH 03031 USA
(603) 886-9400
Fax: (603) 889-1844
www.controlair.com
sales@controlair.com