

TYPE 400
General Service Pressure Regulator

INTRODUCTION

The Type-400 General Service Pressure Regulator is an air or gas service unit designed for instrumentation and general purpose use. This unit is reliable and has excellent stability and repeatability. In addition, all units are irridite coated and finished with baked epoxy paint for corrosion resistant construction necessary for harsh industrial environments. Maximum allowable inlet pressure is 250 psi. Operating temperatures are 0 to 160°F. The Type-330 has low capacity internal relief which provides very limited down-stream over pressure protection. Note: Non-relieving version does not provide internal relief. To avoid exceeding outlet pressure limits in service, a pressure-relieving or pressure-limiting device should be provided.

SPECIFICATIONS

Port Size	1/4" NPT
Output Ranges	0-10 psig (0-0.7 BAR), 0-30 psig (0-2 BAR), 0-60 psig (0-4 BAR), 0-120 psig (0-8 BAR)
Maximum Supply Pressure	250 psig (17 BAR)
Mounting	Pipe, bracket or panel
Flow Capacity	20 scfm (660 NI/min) at 100 psig (7 BAR) supply with 20 psig(1.4 BAR) output
Exhaust Capacity	0.1 scfm (3 NI/min) with downstream pressure 5 psig (0.3 BAR) above set point
Sensitivity	1" (2.5 cm) of water
Air Consumption	Less than 5 scfh (2.5 NI/min)
Effect of Supply Pressure Variation	Less than 0.2 psig (0.01 BAR) for 25 psig (1.7 BAR) change
Temperature Limits	-20°F to 160°F (-29°C to 71°C)
Weight	0.84 lb (0.38 kg)

INSTALLATION

Clean all pipelines to remove dirt and scale before installation. Apply a minimum amount of pipe compound to the male threads of the fitting only. Install the regulator as close as possible to the instrument or tool it is to service. Start with the third thread back and work away from the end of the fitting to avoid contaminating the regulator. Install the regulator in the air line. The words "IN" and "OUT" are cast into the body to indicate the direction of flow. Tighten all connections securely. If a lubricator is to be used in the system, install it downstream.



WARNING: Only qualified personnel should install or service a regulator. Regulators should be installed, operated, and maintained in accordance with international and applicable codes and regulations, and ControlAir instructions. If the regulator vents fluid or a leak develops in the system, it indicates that service is required. Failure to take the regulator out of service immediately may create a hazardous condition. Personal injury, equipment damage, or leakage due to escaping fluid or bursting of pressure-containing parts may result if this regulator is over pressured or is installed where service conditions could exceed the limits given in the Specifications section, or where conditions exceed any rating of the adjacent piping or piping connections. To avoid such injury or damage, provide pressure-relieving or pressure-limiting devices (as required by the appropriate code, regulation, or standard) to prevent service conditions from exceeding limits. Additionally, physical damage to the regulator could result in personal injury and property damage due to escaping fluid. To avoid such injury and damage, install the regulator in a safe location. The internal relief valve in the Type-400 regulators does not provide full overpressure protection. The internal relief valve is designed for minor seat leakage only.

OPERATION

Prior to turning on supply air, back out adjusting screw until there is no compression on the range spring. After turning supply pressure on, turn the adjusting screw clockwise until the desired output pressure is reached.



WARNING: To avoid personal injury resulting from sudden release of pressure, isolate the regulator from all pressure before attempting disassembly.

MAINTENANCE

A repair kit is available for the Type-400. To install replacement parts:

1. Order kit as described in exploded view below.
2. Shut off air supply. Back out adjusting screw.
3. Remove 4 screws and bottom plug. Then remove all parts.
4. Replace appropriate parts with items from kit.
5. Clean all parts and reassemble.

Contact factory with any questions.



WARNING: To avoid personal injury, property damage, or equipment damage caused by sudden release of pressure or explosion of accumulated gas, do not attempt any maintenance or disassembly without first isolating the regulator from system pressure and relieving all internal pressure from the regulator.



WARNING: The materials of the Type-400 are compatible with natural gas. The user should be warned, however, that the Type-400 regulator may vent some gas to the atmosphere. In hazardous or flammable service, vented gas may accumulate and cause personal injury, death, or property damage due to fire or explosion. If regulator is used in a hazardous gas service area, the regulator must be vented to a remote, safe location away from air intakes or any other hazardous area. The vent line or stack opening must be protected against condensation or clogging. Do not use these products where pressure and temperatures can exceed those listed under specifications.

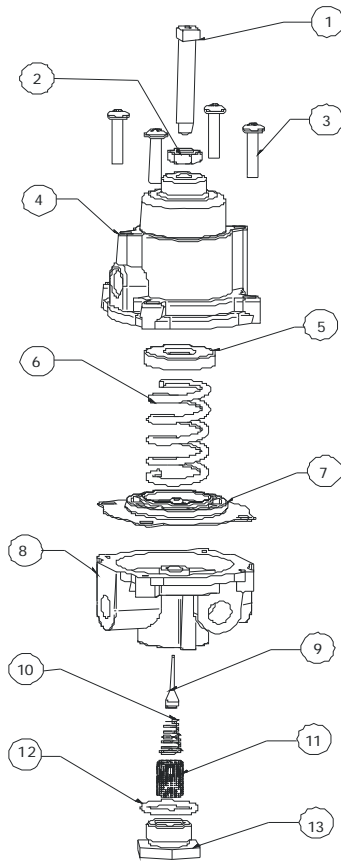

Parts List	
ITEM	DESCRIPTION
1	Sq. Hd. Adjusting Screw
2	Nut, Lock
3	Build Screw
4	Bonnet
5	Guide, Spring
6	Spring, Range
7	*Diaphragm Assembly
8	Body
9	*Pintle, Valve
10	*Spring, Pintle
11	*Screen
12	*O-ring, Plug
13	Plug, Bottom

All items marked with an asterisk (*) will be included in the repair kit. Other parts may be ordered separately by specifying the item number, part name, and the part number of the regulator for which the parts are intended.

Repair Kit Part Number: 449-871-014

LIMITED WARRANTY & DISCLAIMER

ControlAir, Inc. products are warranted to be free from defects in materials and workmanship for a period of eighteen months from the date of manufacture, provided said products are used according to ControlAir, Inc. recommended usages. ControlAir, Inc.'s liability is limited to repair of, refund of purchase price paid for, or replacement in kind of, at ControlAir, Inc.'s sole option, any products proved defective. ControlAir, Inc. reserves the right to discontinue manufacture of any product or change product materials, design or specifications without notice. Note: ControlAir does not assume responsibility for the selection, use, or maintenance of any product. Responsibility for the proper selection, use, and maintenance of any ControlAir product remains solely with the purchaser and end user.